

Location #1 "HIGH" P=Post player and also #5  
Post player has the ball approximately 6-8 steps beyond 3-point arc.

## THE BACKDOOR OFFENSE

### Part One ----- Foundations of the Backdoor Offense

#### A. Location of Post

- 1.high
- 2.Low
- 3.Side Post
4. Top of Key

### Part Two ----- High to Low Series

- A. Circle entry
- B. "X" entry
- C. Back Screen entry
- D. Circle Entry 5 to 1
- E. Flares
- F. Special Option
- G. Tiger Option
- H. Black Option
- I. Black Option to Low

### Part Three ----- Side / Shuffle Cut Series to Top of Key Series

- A. Top of Key Series
- B. Orange Series
  1. Orange option
- C. Blue Option
- D. White Option

### Part Four ----- Additional Options

- A. Rocket
  1. Rocket Option
- B. Spread Option
- C. Cardinal Option
- D. Astro Option

### Part Five ----- Special Sets

- A. High Series "Flare"
- B. Scissors
- C. Iso
- D. Triangle
- E. Circle Special
- F. Dribble Entry
- G. State
- H. Shirt

- I. Lob Set
- J. Sprint
- K. Sprint Pressure release
- L. UCLA
- M. Shuffle Cut

Part Six ----- Breakdown Drills

- A. 2-0 Back door lay-up
- B. 2-0 Hand off
- C. 3-0 Flares
- D. 4-0 Flares to penetration and Pitch.

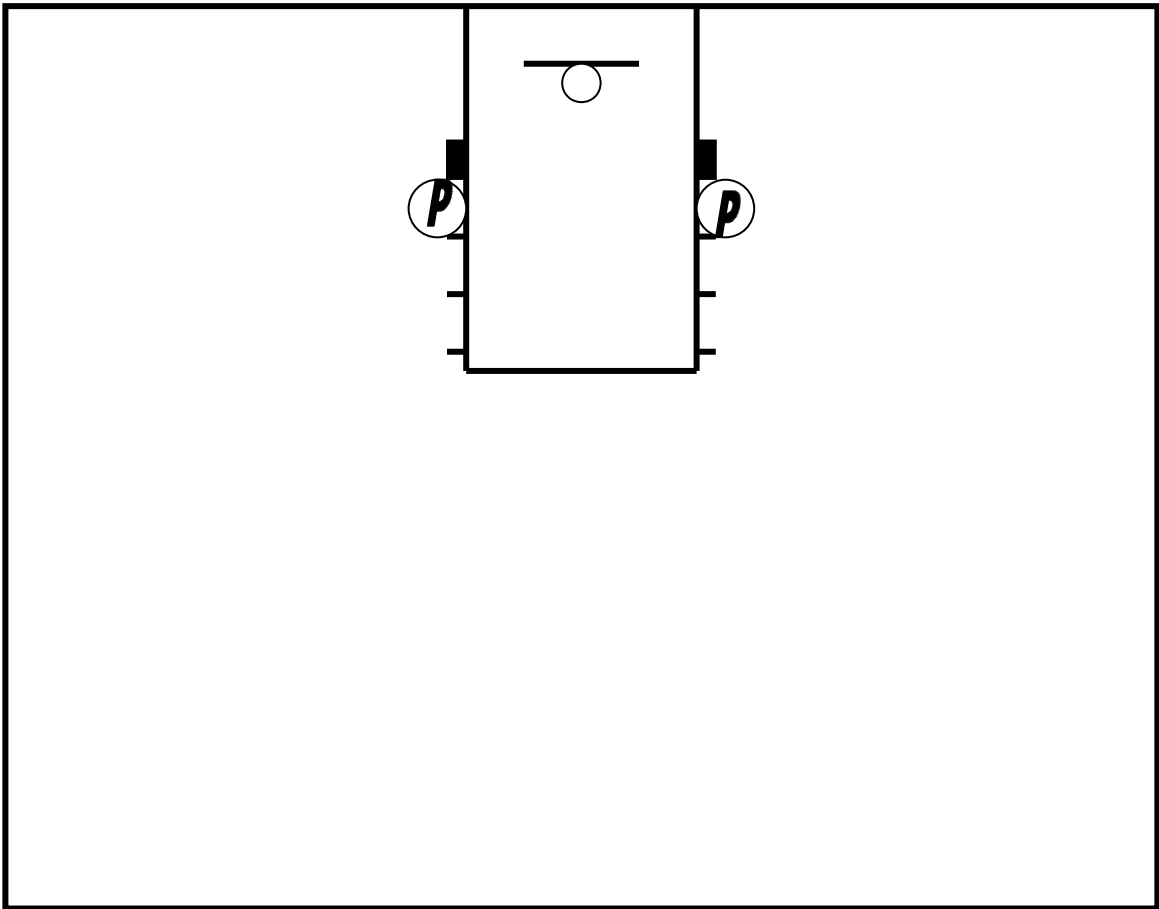

Location #2 "Low Post"

Post player can occupy either block looking to score.

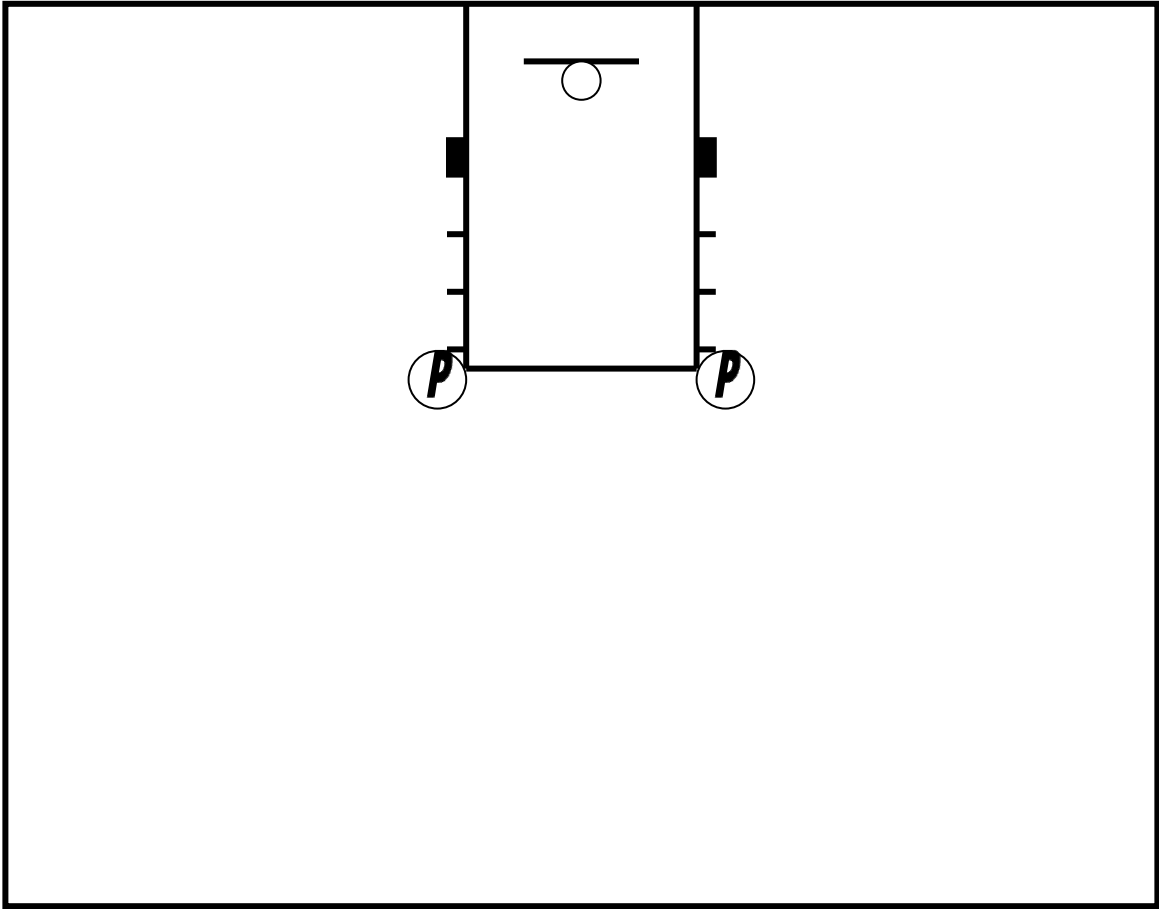

Location #3 "Side Post"  
Post player is anchored at either elbow.

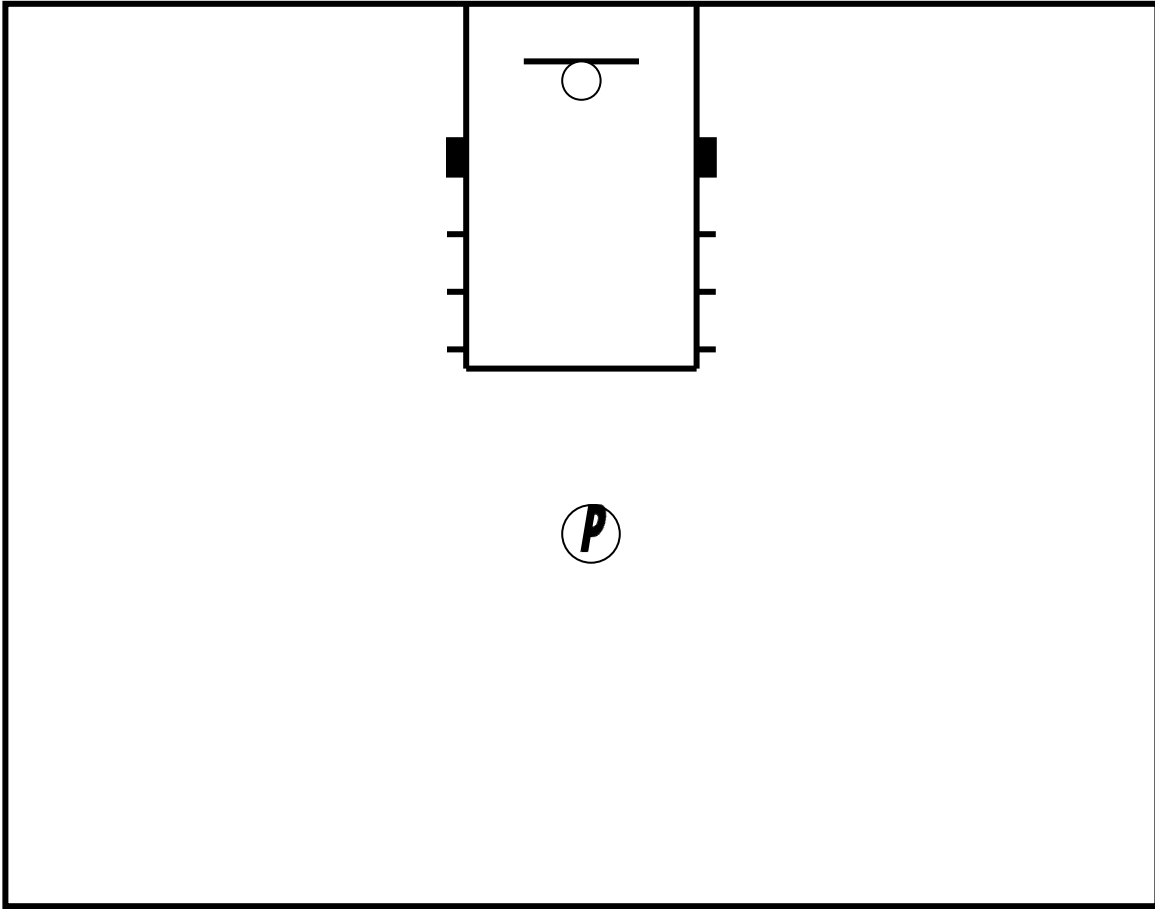

Location #4 "Top of Key"

Post player occupies spot approximately one step beyond 3- point arc.

## PART 2 HIGH LOW SERIES

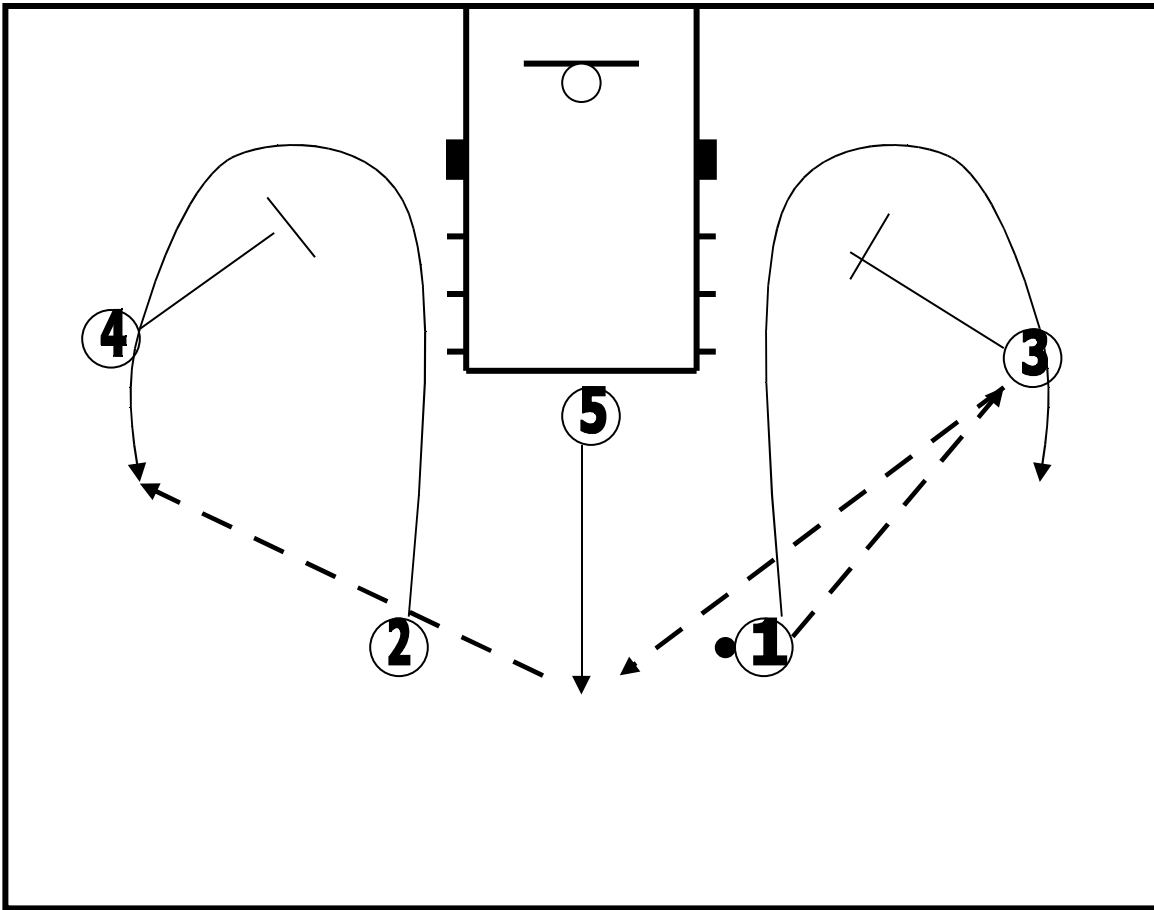

### “High to Low Series”

#### “Circle Entry”

Players are in a 2-3 high set

1 passes to 3, 3 pass to 5 on a step out.

1 and 2 are basket cutting, then coming off screens by 4 and 3.

5 can pass to 1 or 2.

3 and 4 look to slip the screens.

If defenders on 1 and 2 “play the play,” then 1 and 2 can fake coming off the screen and back door for a lay-up.



## PART 2 HIGH LOW SERIES

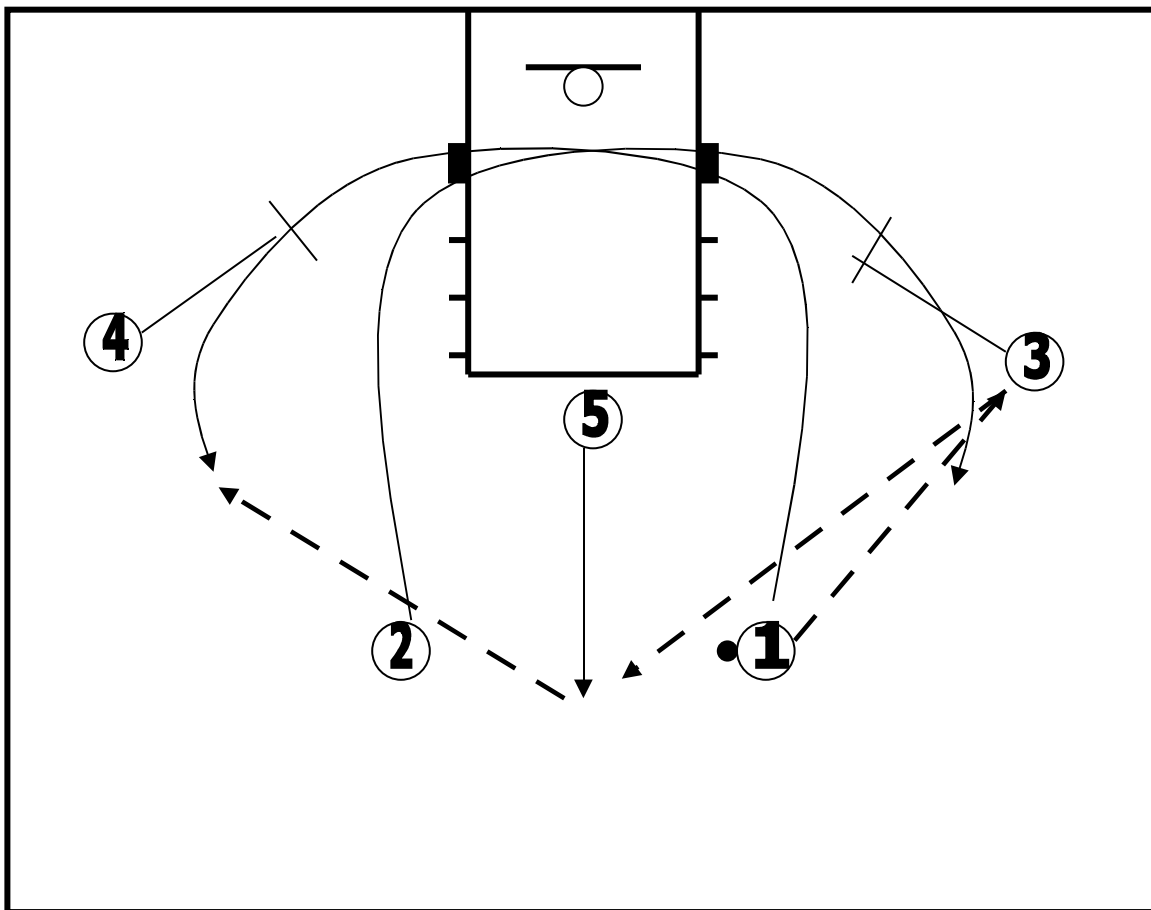

### “High to Low Series” “X” Entry

Players are in a 2-3 high set

2 passes to 4, 4 pass to 5 on a step out

1 and 2 basket cut, criss-cross, 2 gets a screen from 3 and 1 gets a screen from 4

5 can pass to 1 or 2 at any time for a jumper off the screen

4 and 3 can look to slip the screens on the switch

## PART 2 HIGH LOW SERIES

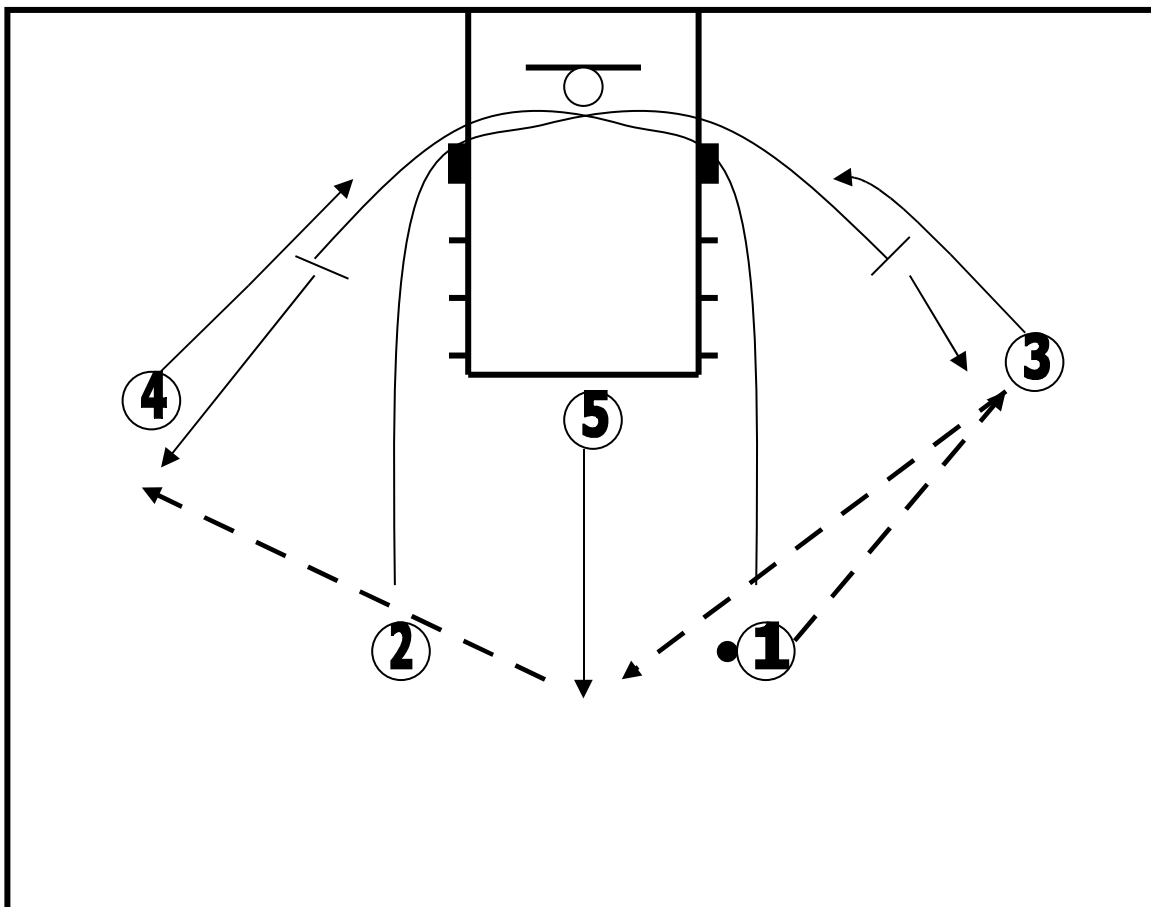

### “High to Low Series” “Back screen” Entry

Players are in a 2-3 high set

1 passes to 3, 3 pass to 5 on a step out

1 and 2 basket cut, criss-cross, set back screens for 3 and 4.

Note: 3 and 4 must wait on the back screen

If 3 and 4 are not open, pass to 1 or 2 on a step out and into continuity offense.

## PART 2 HIGH LOW SERIES

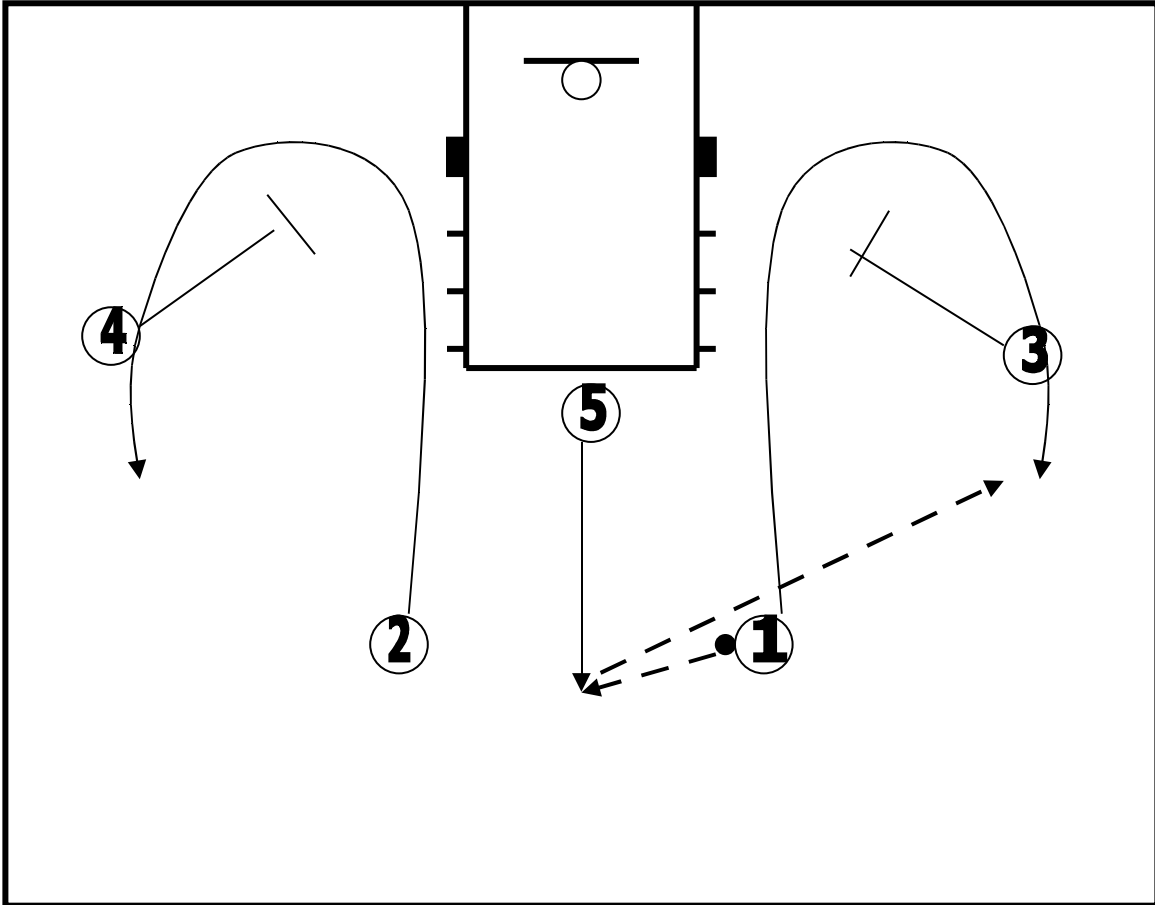

“High to Low Series”

Offense has executed the circle entry  
5 passes to 1.

## PART 2 HIGH LOW SERIES

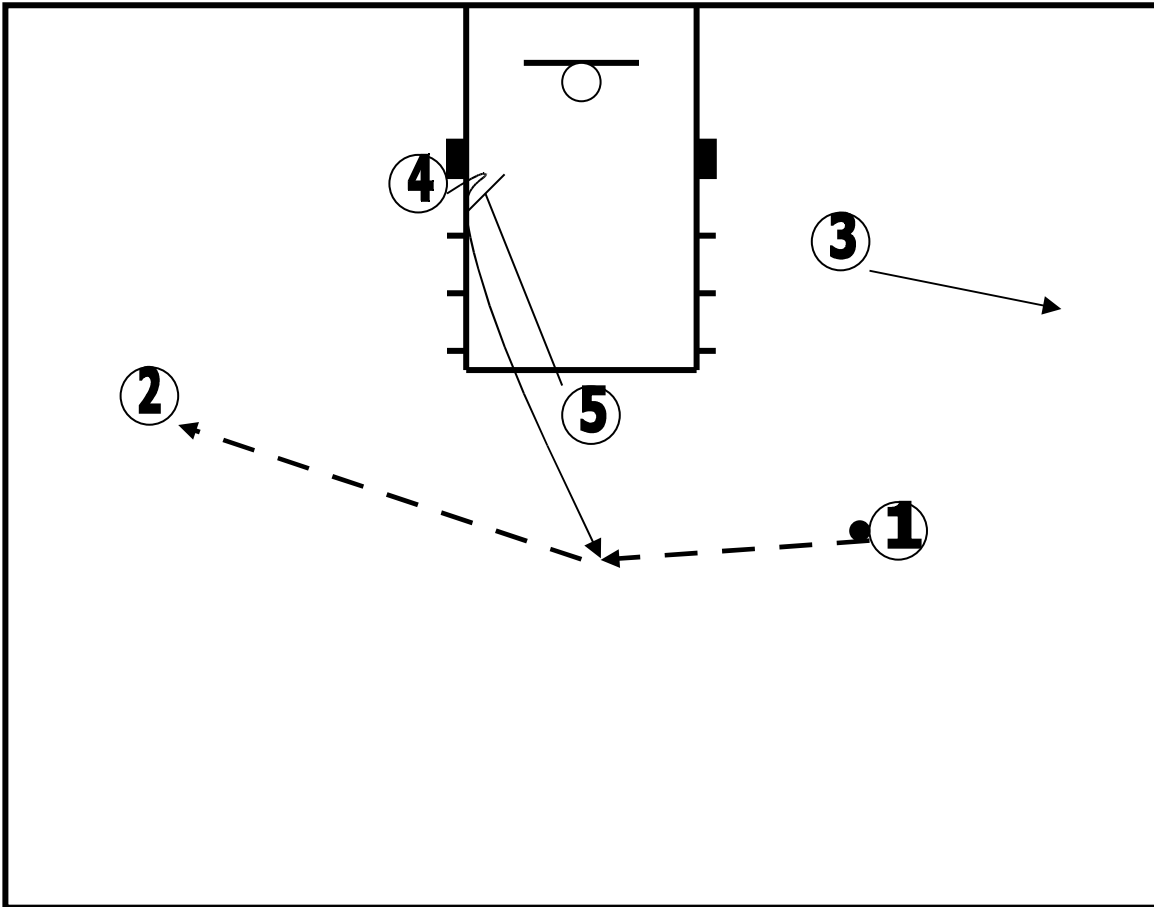

“High to Low Series”

5 screens for 4.

1 passes to 4

4 quickly reverses the ball to 2.

PART 2 HIGH LOW SERIES

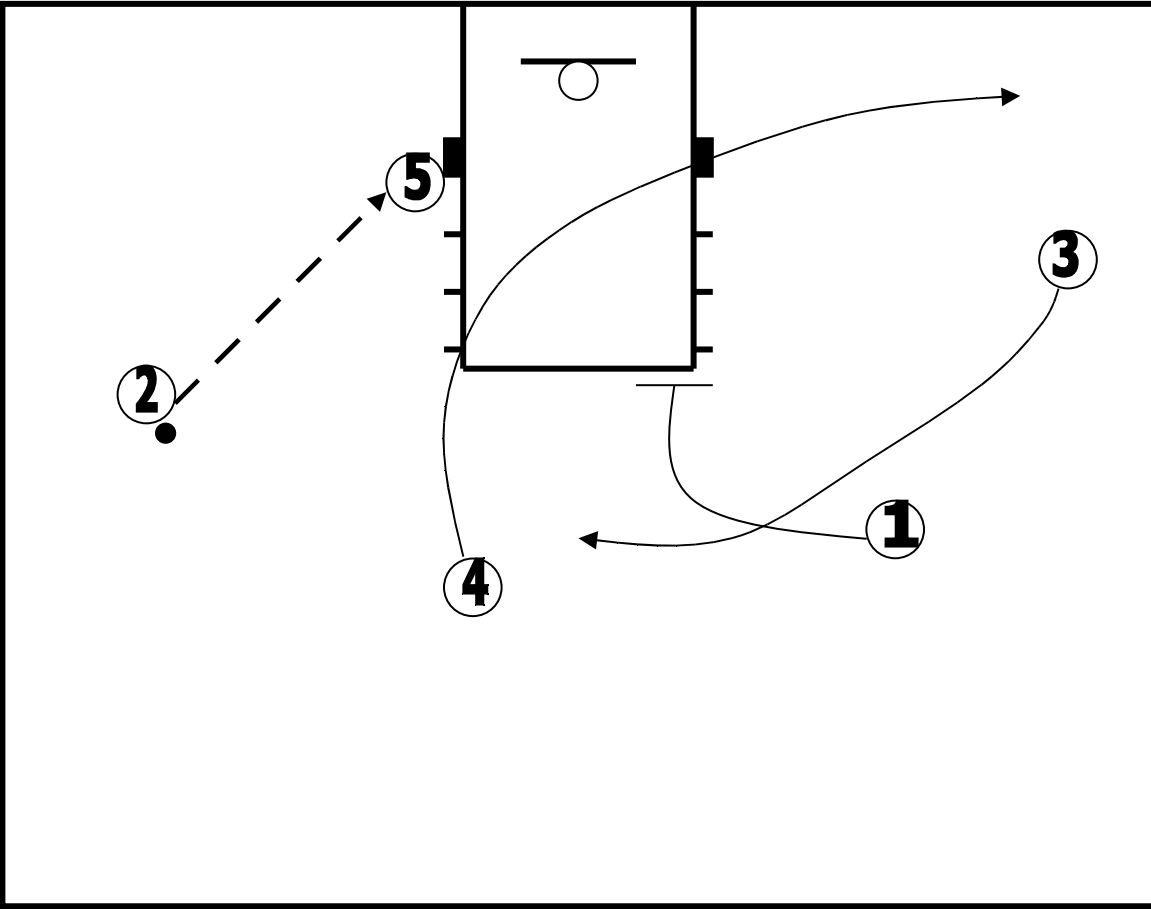

“High to Low Series”

- 4 cuts to weak side corner after passing to 2.
- 2 passes to 5 in the post looking for a shot
- 1 screens 3 coming to the top of the key.

## PART 2 HIGH LOW SERIES

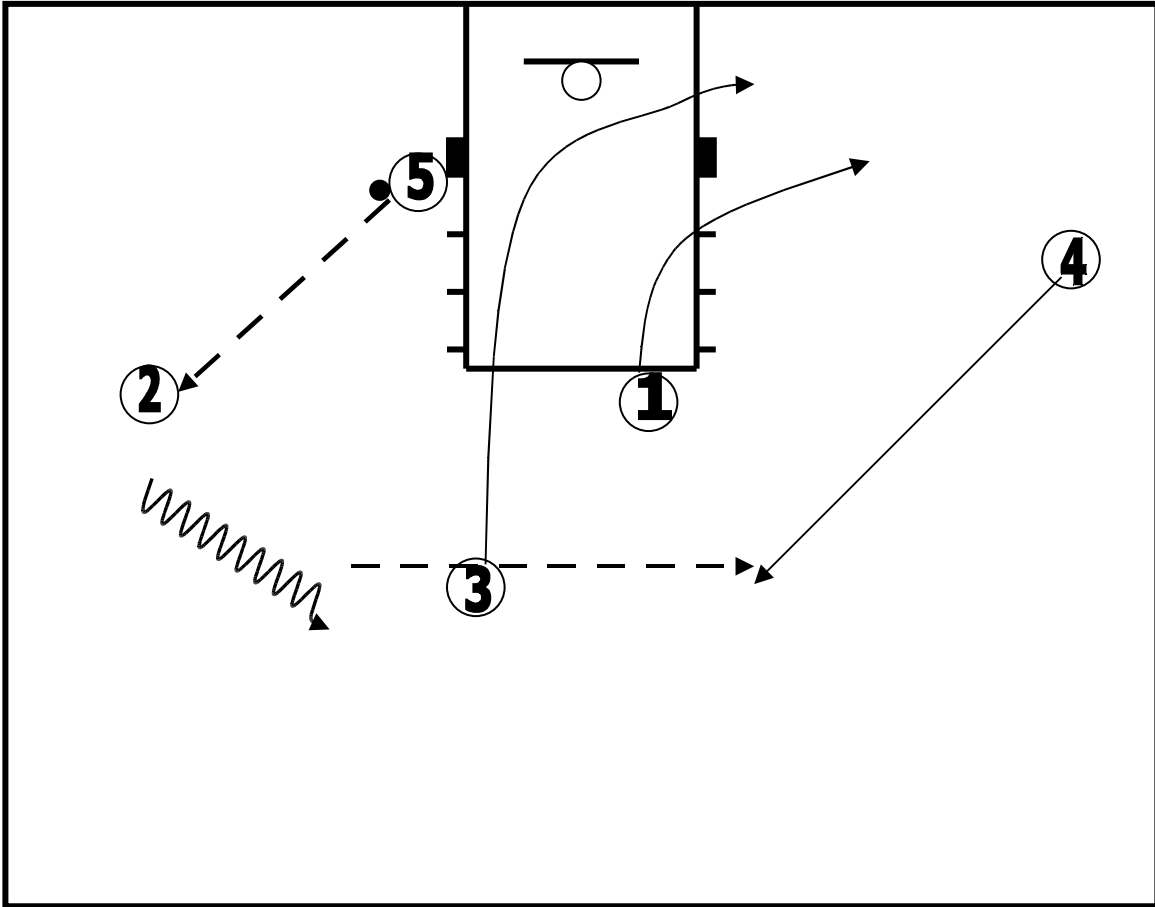

“High to Low Series”

2 gets return pass from 5  
2 dribbles out 3 and 1 passes to 4

## PART 2 HIGH LOW SERIES

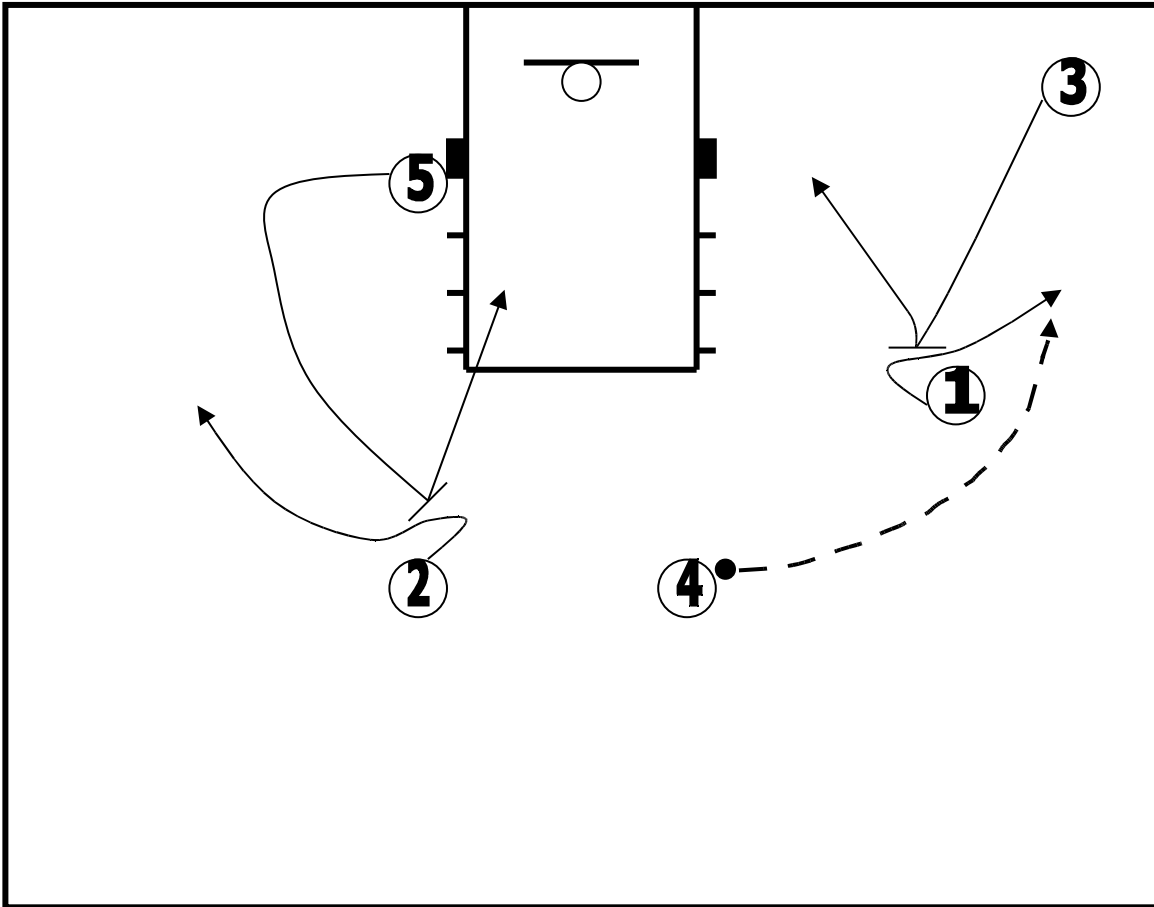

### “High to Low Series” Flare Screens

After passing to 4, 5 sets a flare screen for 2

3 is setting a flare screen for 1

5 and 3 can slip screens for easy lay up

4 passes to 1

## PART 2 HIGH LOW SERIES

“High to Low Series” Special Option

After 4 passes to 1, 4 down screens for 5

1 passes to 5, who quickly reverses the ball to 2.

4 up screens for 5 for a post isolation

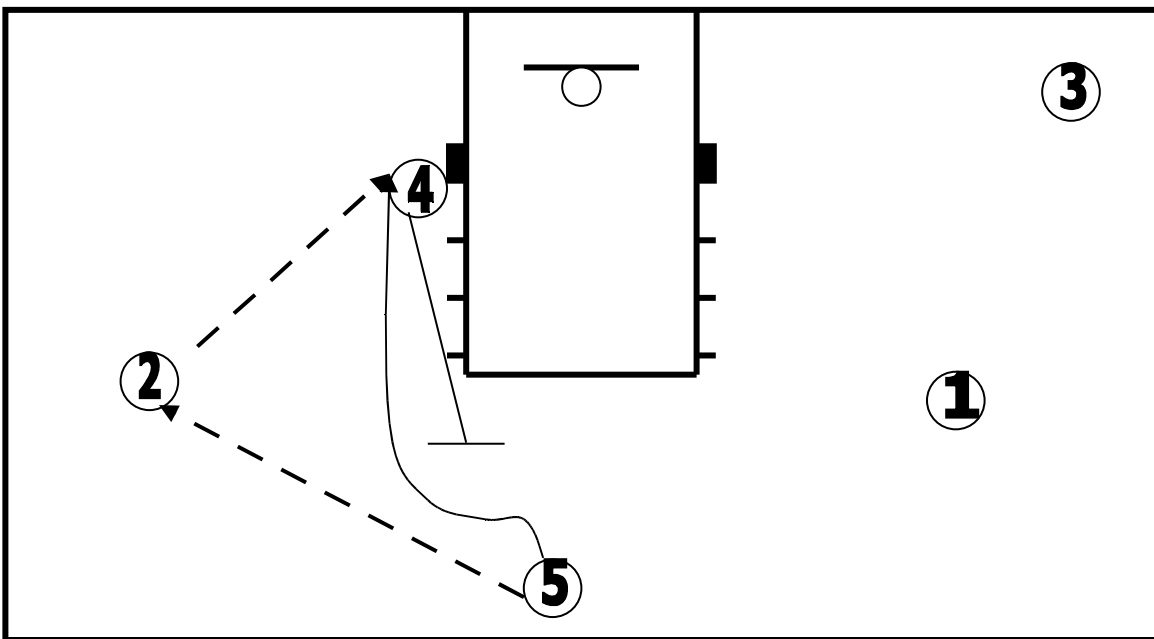
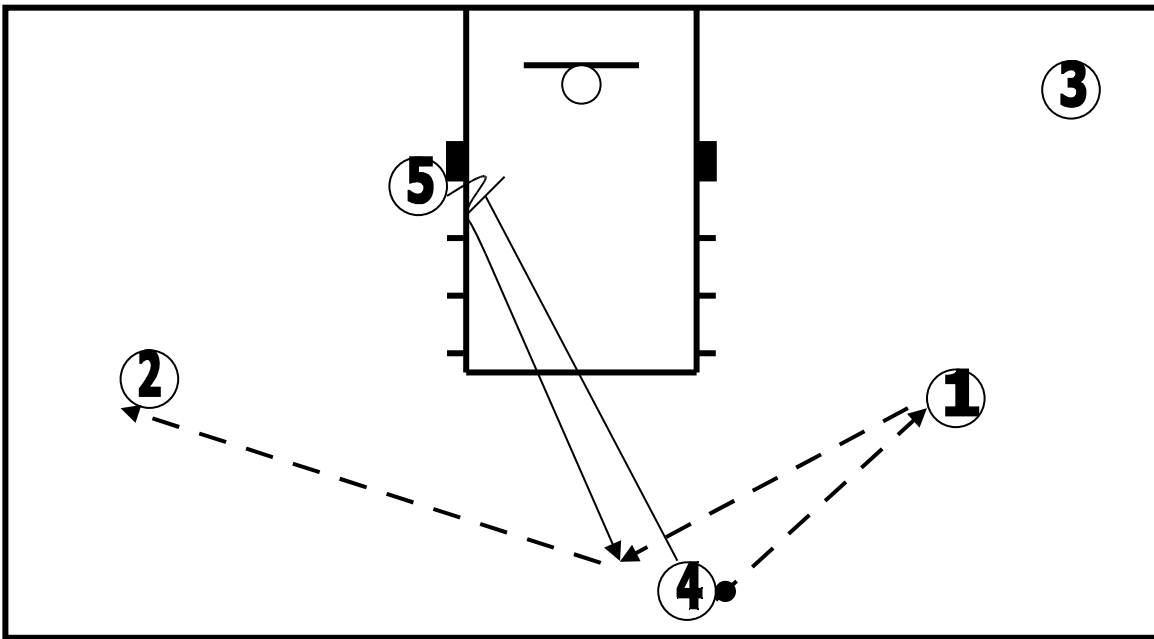





## PART 2 HIGH LOW SERIES

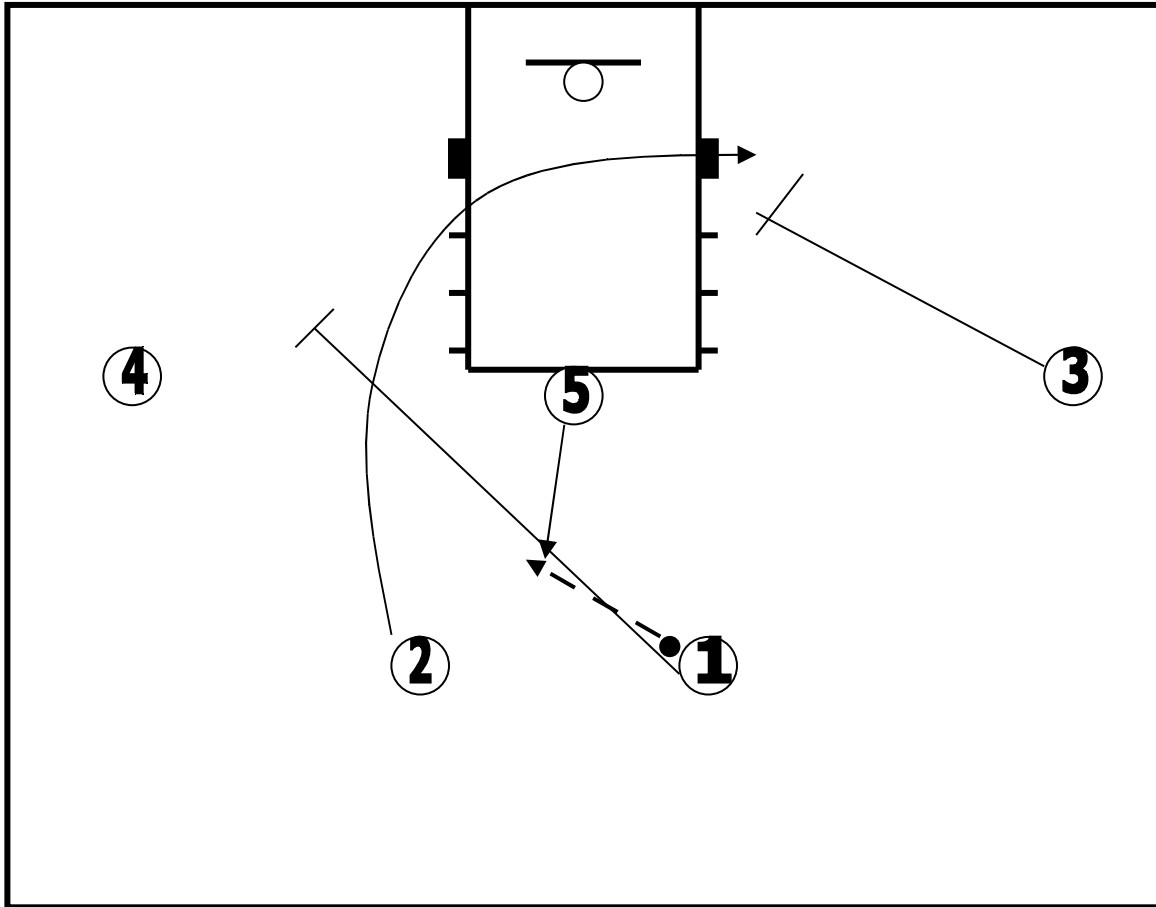

### “High to Low Series” Tiger Option

- 2 cuts through on pass to 5
- 1 runs to set screen for 4, 4 can back cut or curl
- 1 can slip the screen
- 3 is down screening for 2

## PART 2 HIGH LOW SERIES

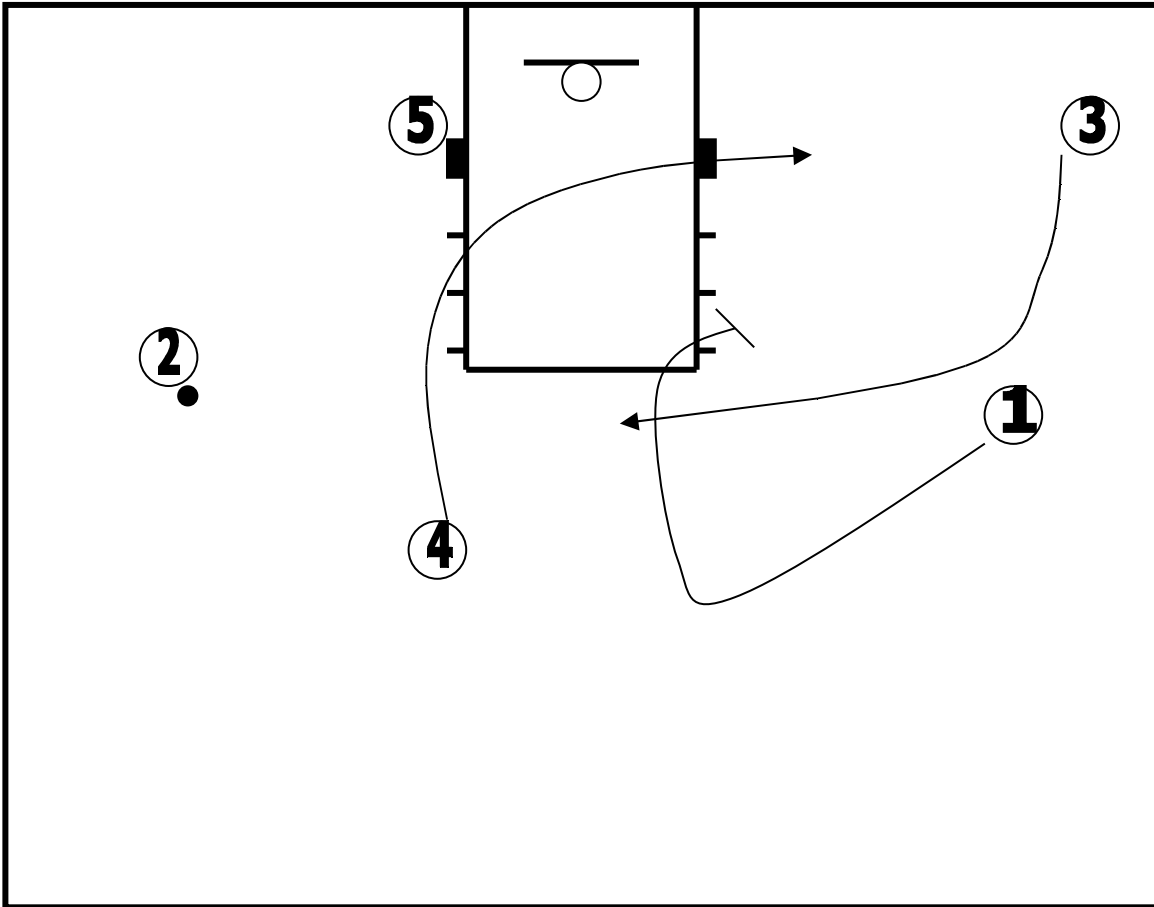

“High to Low Series”: Special option to low series

2 has the ball, 4 cuts to opposite corner

5 looks to post

1 screens for 3

## PART 2 HIGH LOW SERIES

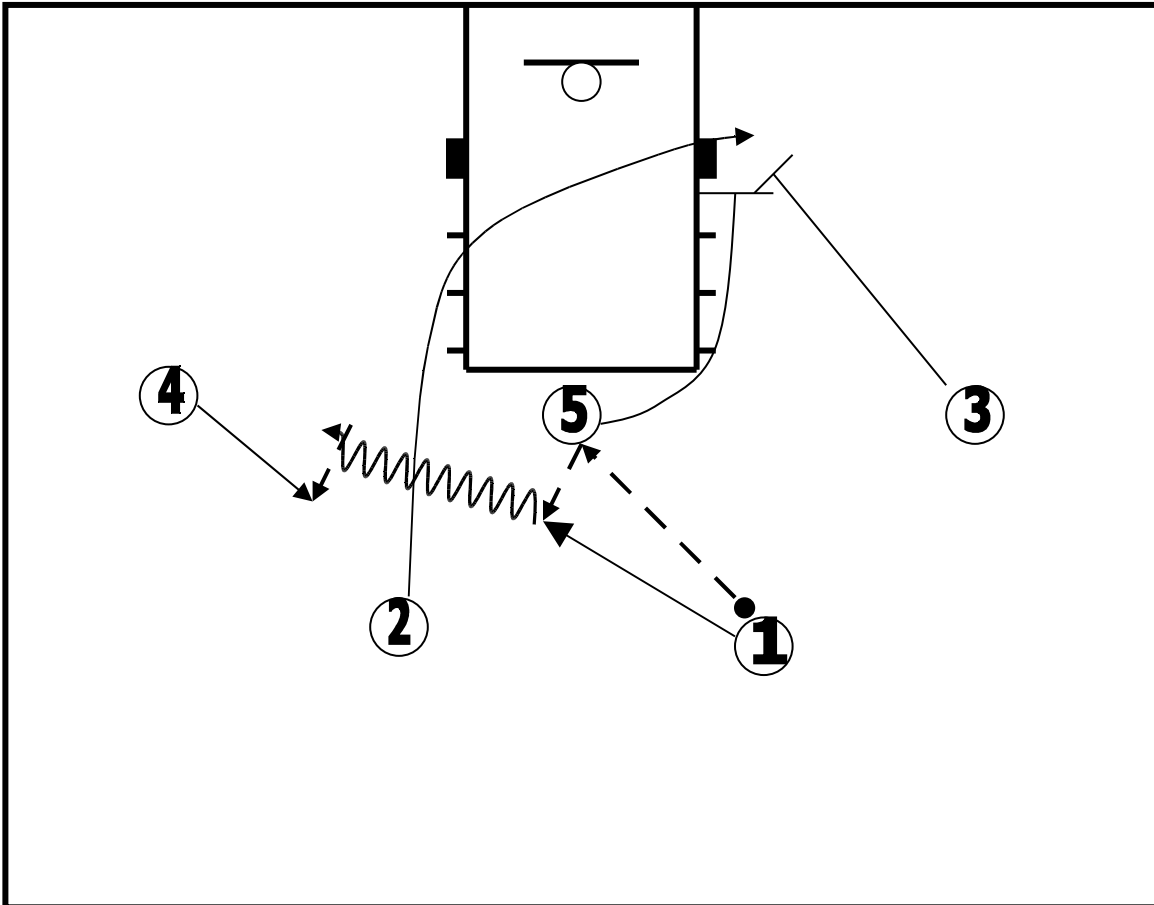

“High to Low Series”: “Black” option

1 passes to 5 on a step out to the “High” position

2 basket cuts hard

1 cuts behind 5 for a return flip pass

5 relocates to set a double screen with 3

4 takes the handoff from 1 and looks to pass to 2 coming off of 3 and 5’s double screen.

## PART 2 HIGH LOW SERIES

“High to Low Series” “Black” option

4 has passed to 2, 2 is not open for the shot

2 now dribbles at 4 and 4 back cuts to the weak side.

1 fills high

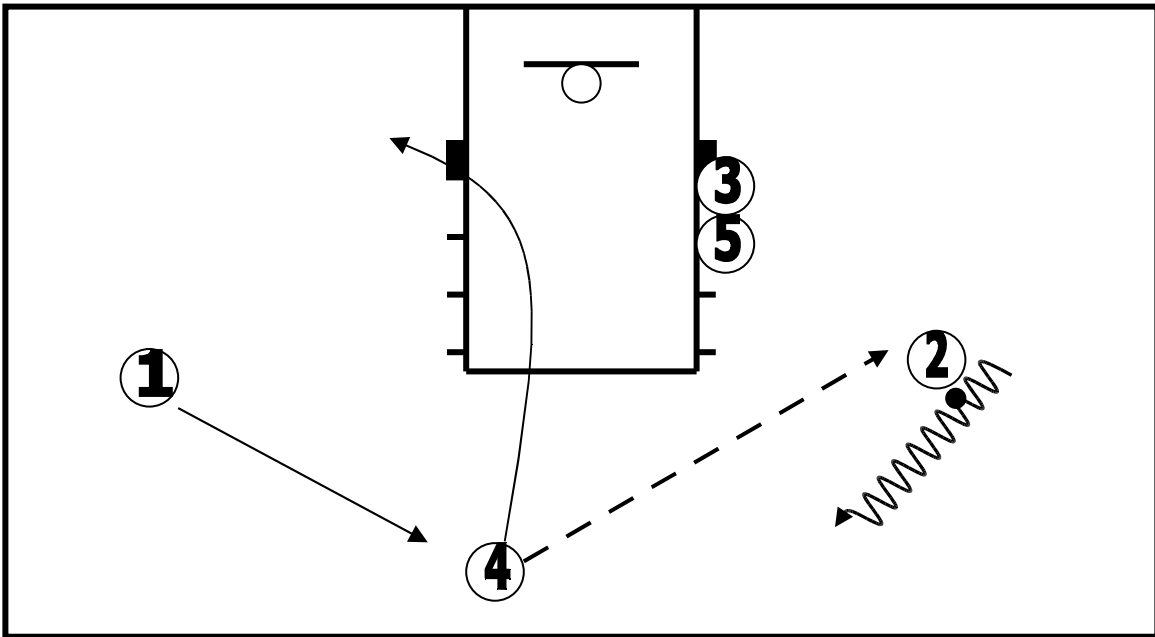

“Black” “option to Low”

1 receives pass from 2

2 fades to the wing

3 now rubs off 5 and gets a pass from 1

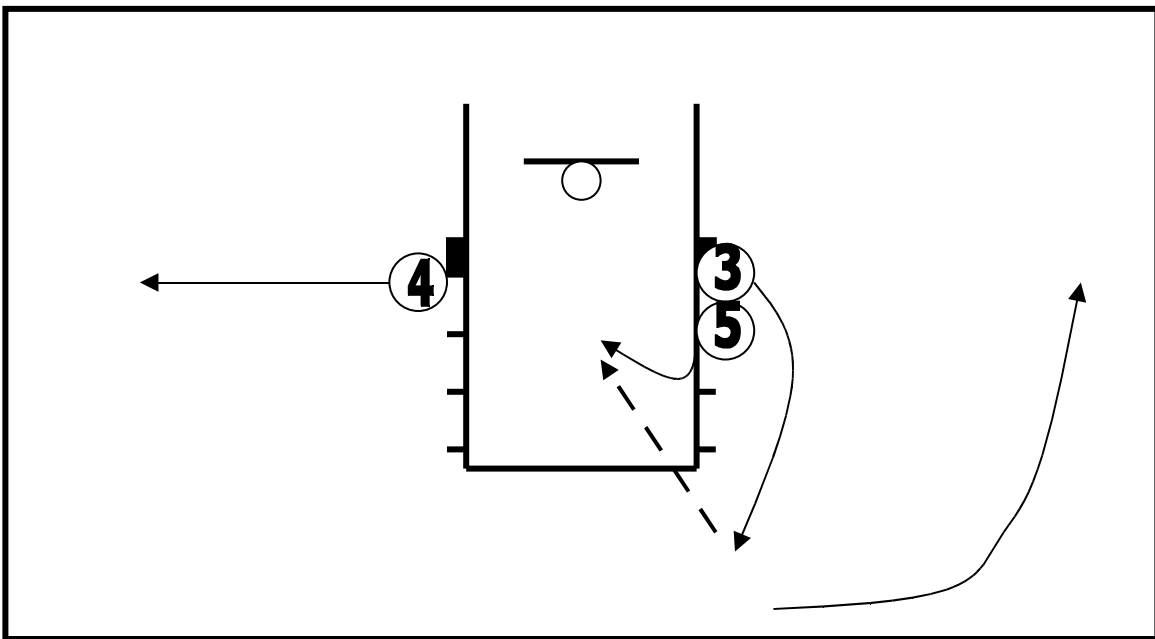

Part Three Side/ Shut **1** Cut Series to top of Key series

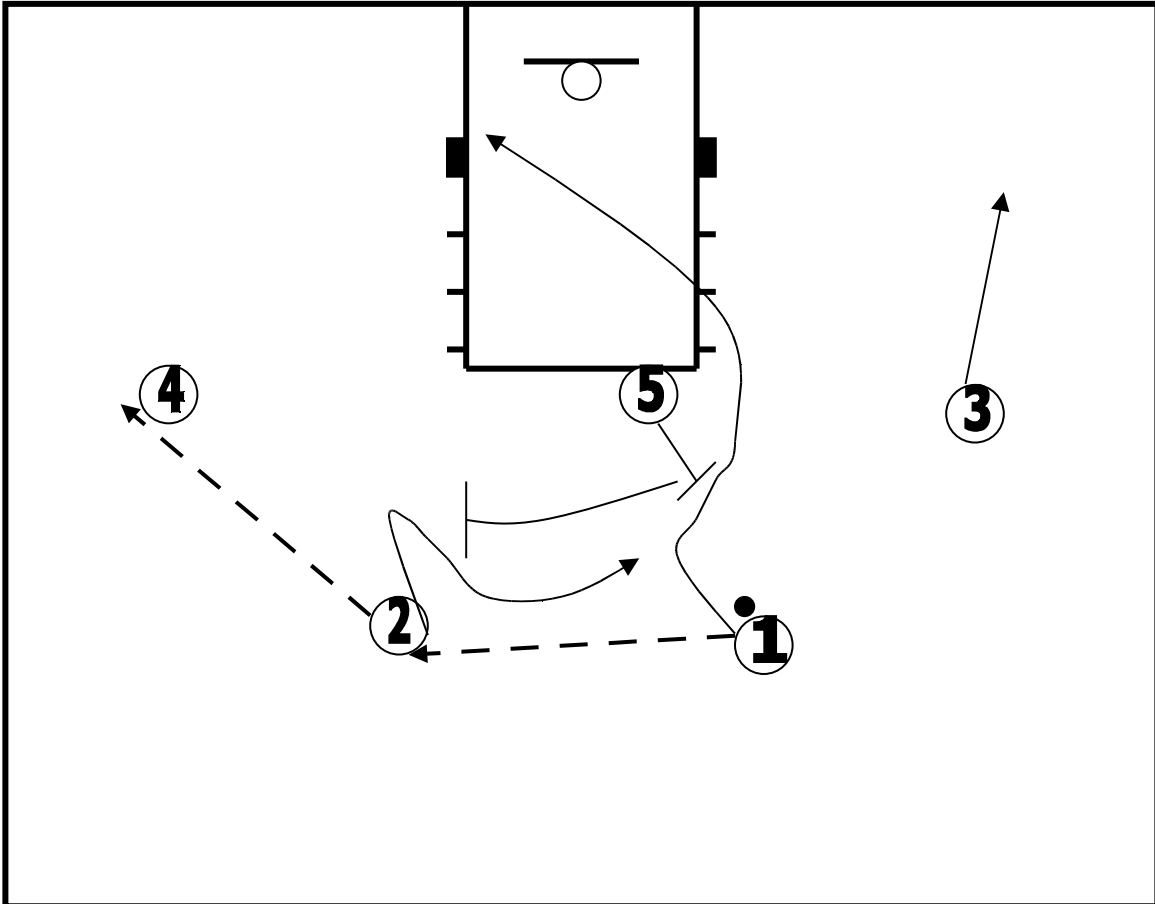

Basic alignment is a 2-3 high set with the postman occupying either elbow  
 1 man reverses the ball to 2, then ball is swung from 2 to 4  
 On the flight of the ball from 2 to 4, 1 is cutting hard off of 5's back screen  
 for a lay up  
 If 1 is not open, 4 looks to pass to 2 off the flare screen from 5.

Part Three Side/ Shuffle Cut Series to top of Key series

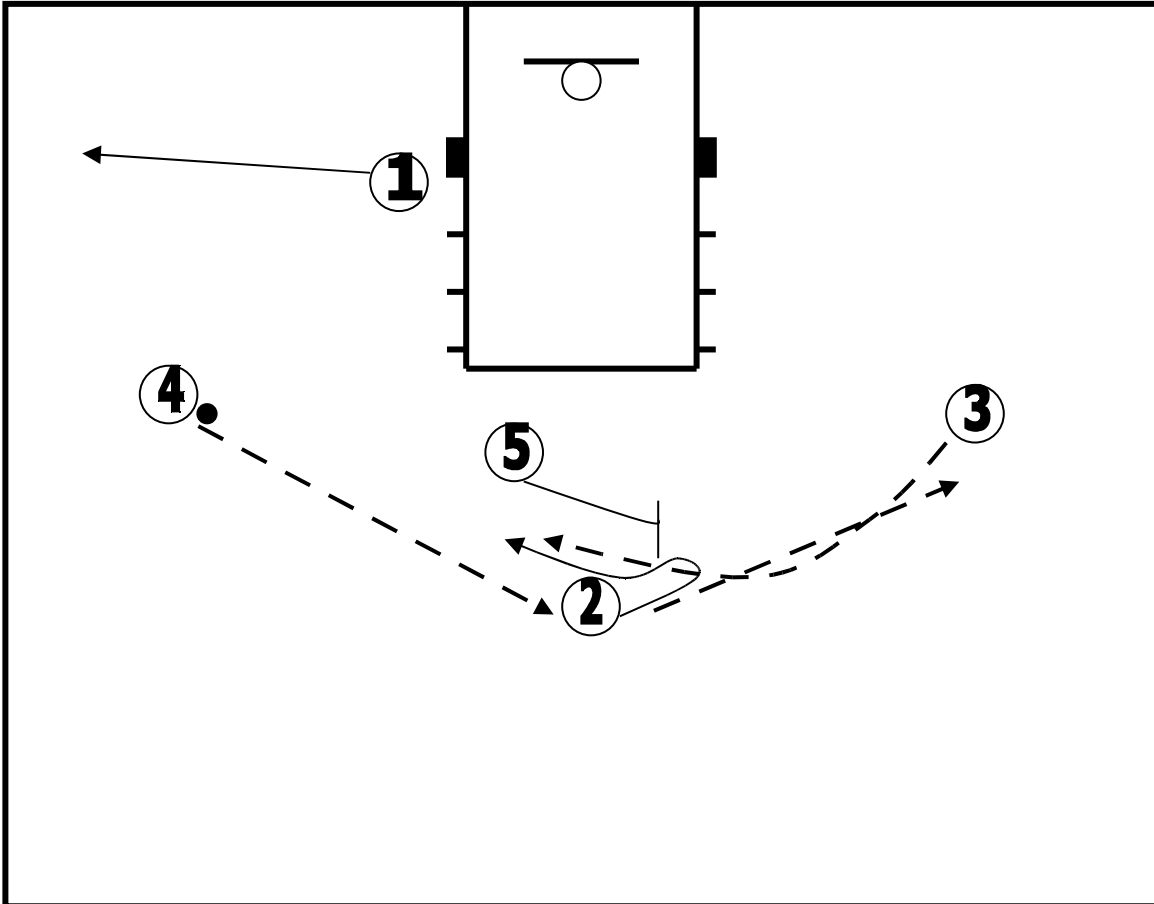

4 passes to 2 but 2 has no jumper

2 swings ball to 3 and 5 sets another flare screen for 2

1 has cleared to the corner.

Part Three Side/ Shuffle Cut Series to top of Key series

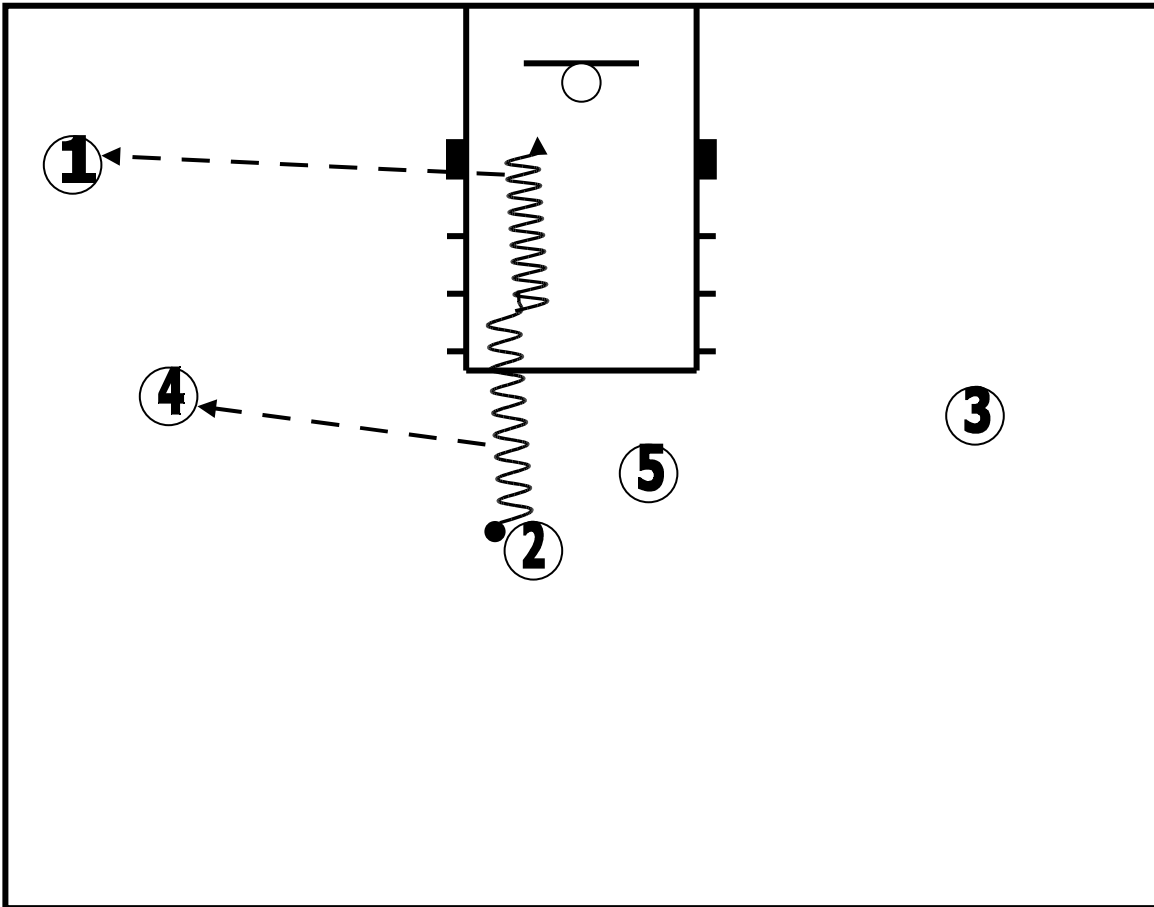

- 2 catches and has the option
- 1-shoot
- 2-drive for a lay up
- 3- kick to 4 or 1 for a jump shot

Part Three Side/ Shuffle Cut Series to top of Key series (Continuity 1A)

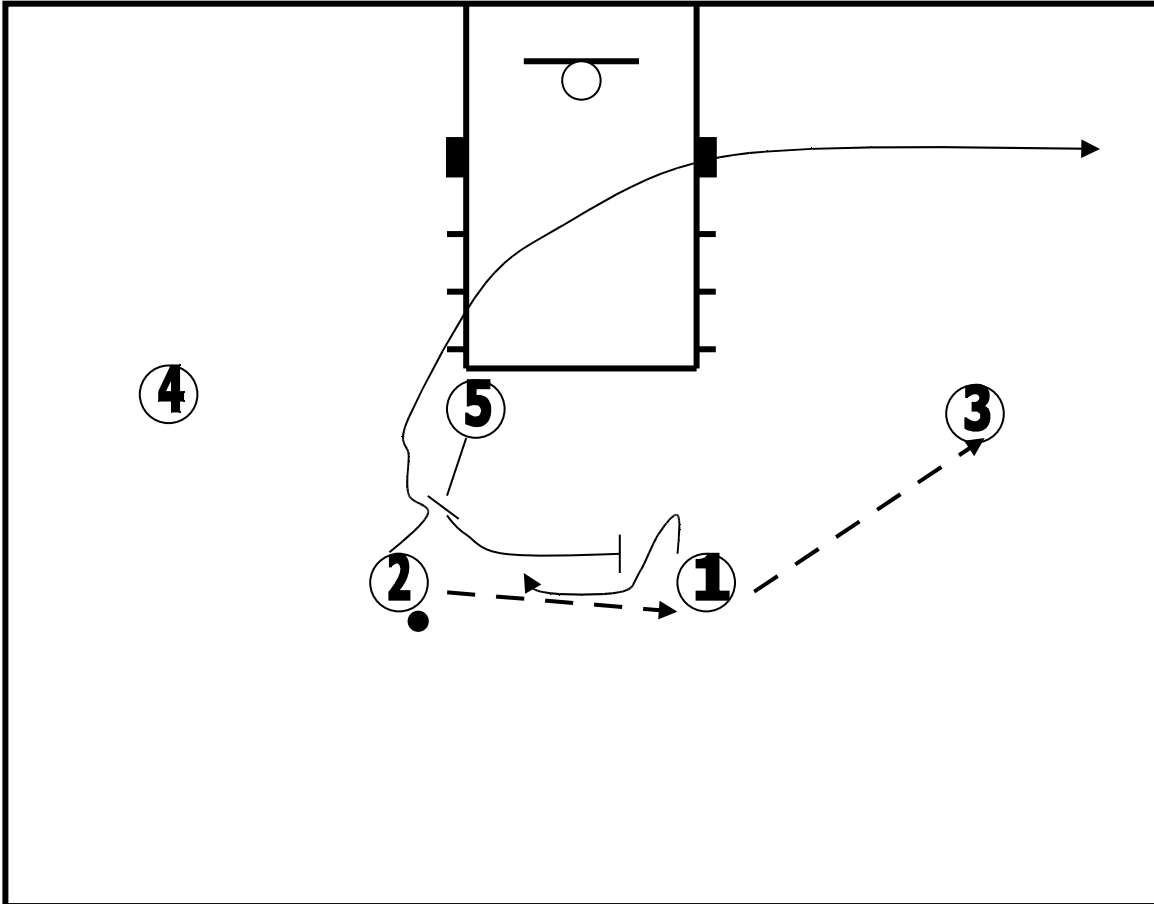

The following two diagrams will illustrate the side/shuffle series as a continuity you desire to run it as such

2 passes to 1 who reverses to 3

2 is cutting off 5's screen on the flight of the ball from 1 to 3

1 receives flare from 5



Part Three Side/ Shuffle Cut Series to top of Key series (Continuity 1B)

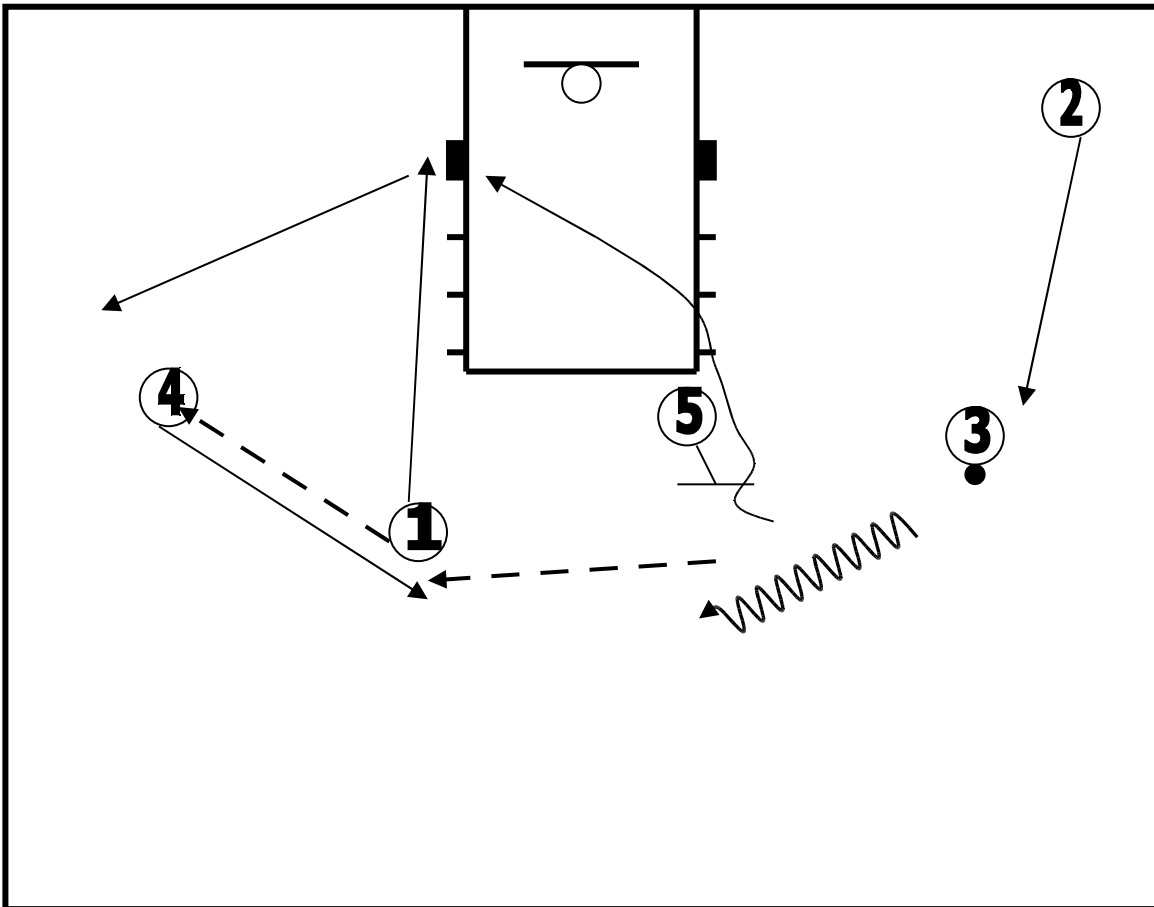

1 was not open off 5's flare screen, so he cuts through  
3 dribbles to the guard spot, 3 passes to 4 who has filled the other guard spot  
4 reverses ball to 1, who has filled the forward spot (as has 2 on the weak side)

On pass from 4 to 1, 3 cuts hard off of 5.

4 will then receive flare from 5 and continuity is established.

Part Three Side/ Shuffle Cut Series to top of Key series

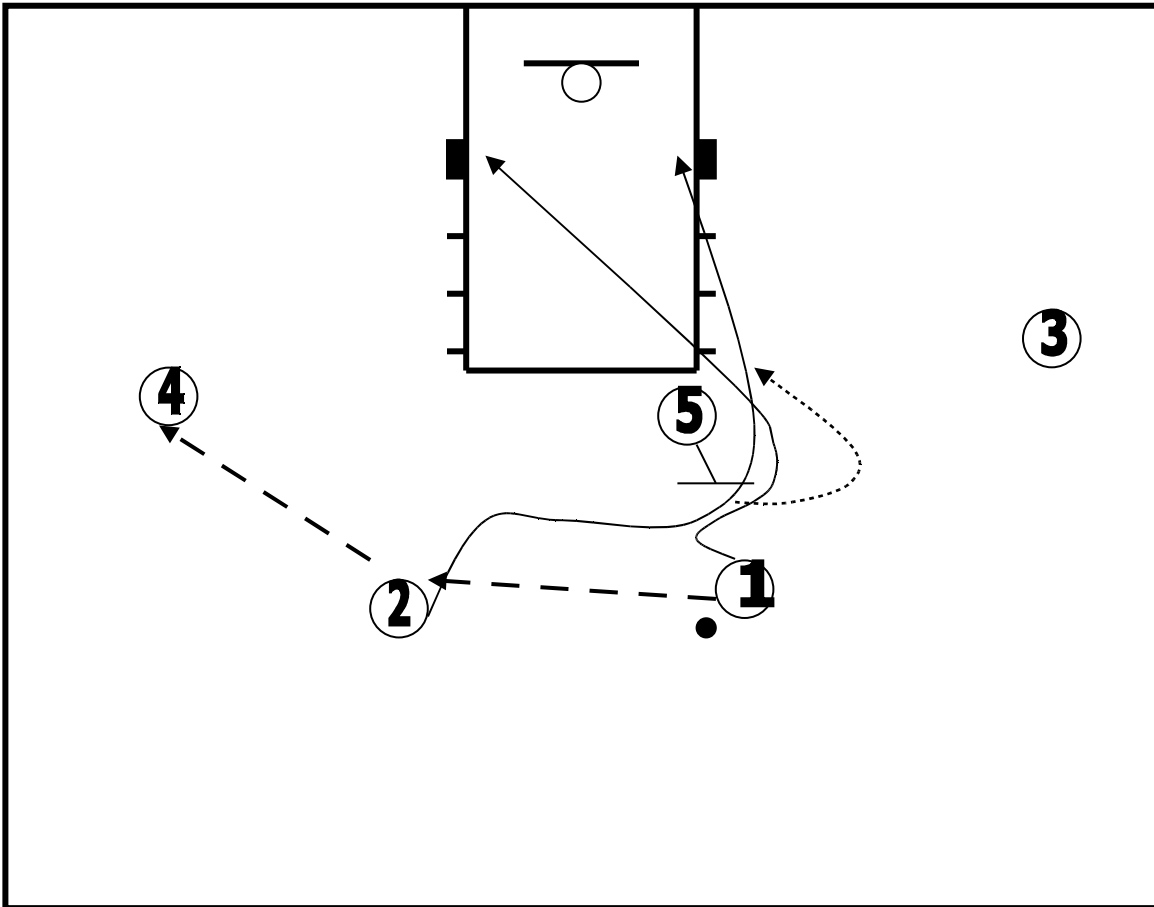

The following diagrams will illustrate the execution of the “side/shuffle” series into “top of the key” series with several special options included  
1 passes to 2 who swings top 4. 1 cuts off 5 looking for a lay up. 2 gets flare from 5 but isn’t open so he cuts through.

Part Three Side/ Shuffle Cut Series to top of Key series

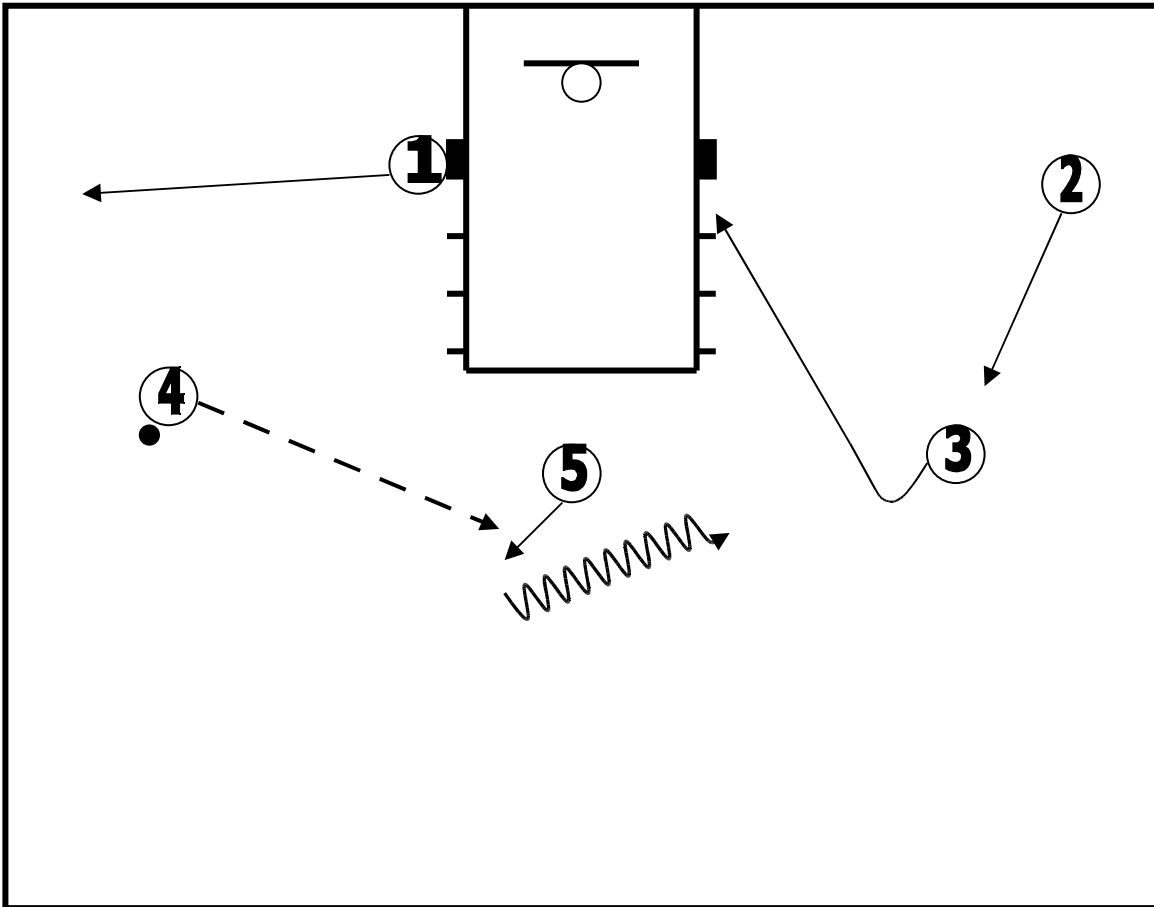

4 passes to 5 on a step out, 5 dribbles hard at 3 who back cuts to the block  
1 has filled weak side corner  
2 steps up for pass from 5

Part Three Side/ Shuffle Cut Series to top of Key series

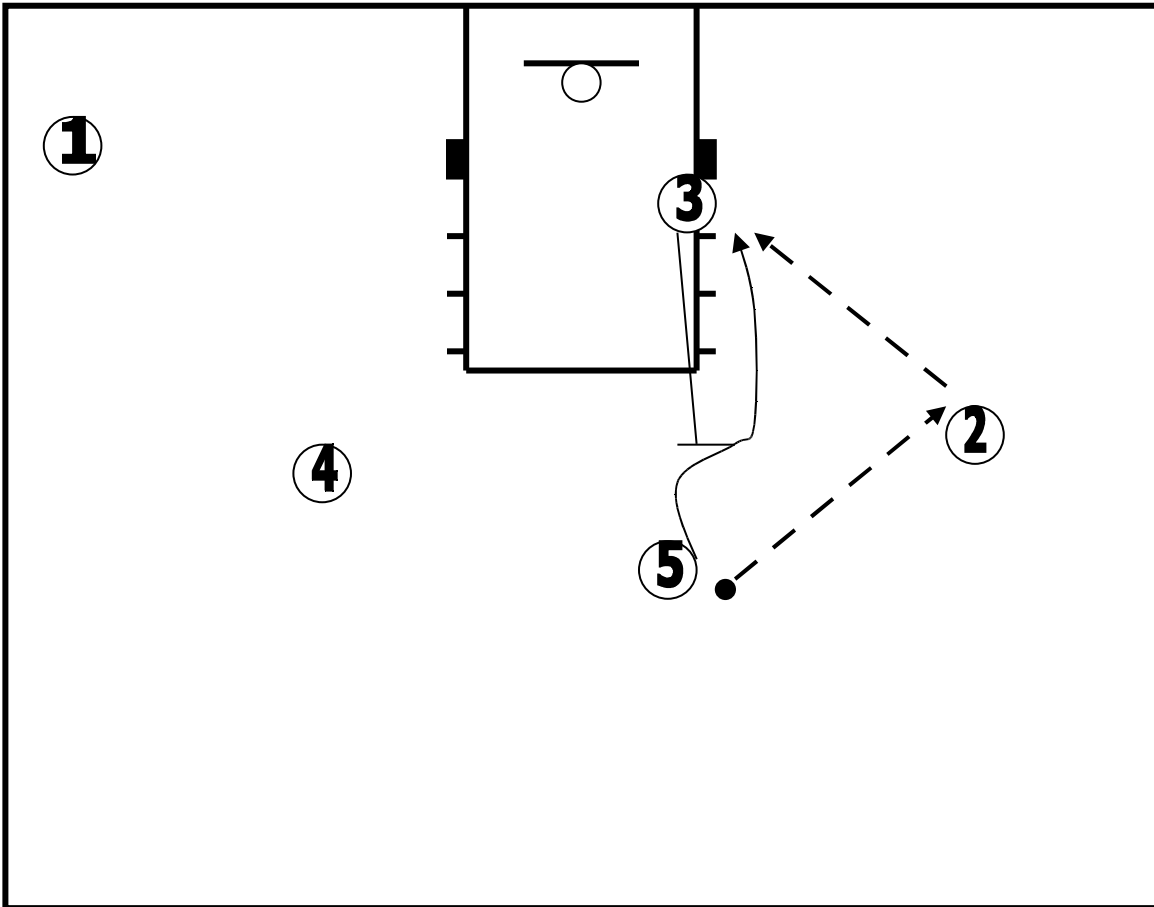

5 passes to 2

5 now receives an up screen from 3 for post isolation

2 can pass to 5 directly or step out and look to feed 5 on a duck in.

### Part Three Side/ Shuffle Cut Series to top of Key series

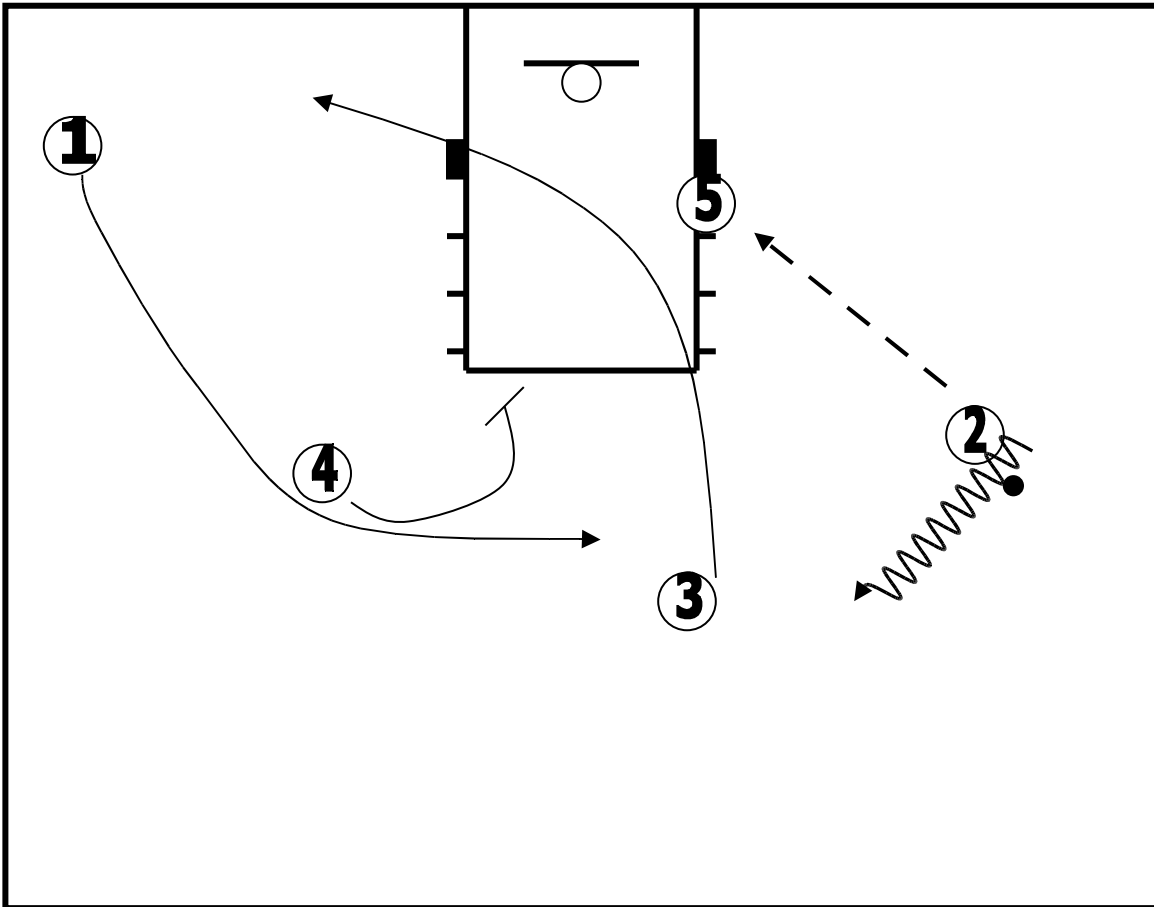

“Orange” option to “Low” series

If defense takes away post isolation by 5 and 3 being denied, 2 dribbles at 3  
–3 back cuts to fill opposite corner

4 screens for 1 and we are now in a “Low” series with 5 occupying the low post

### Part Three Side/ Shuffle Cut Series to top of Key series

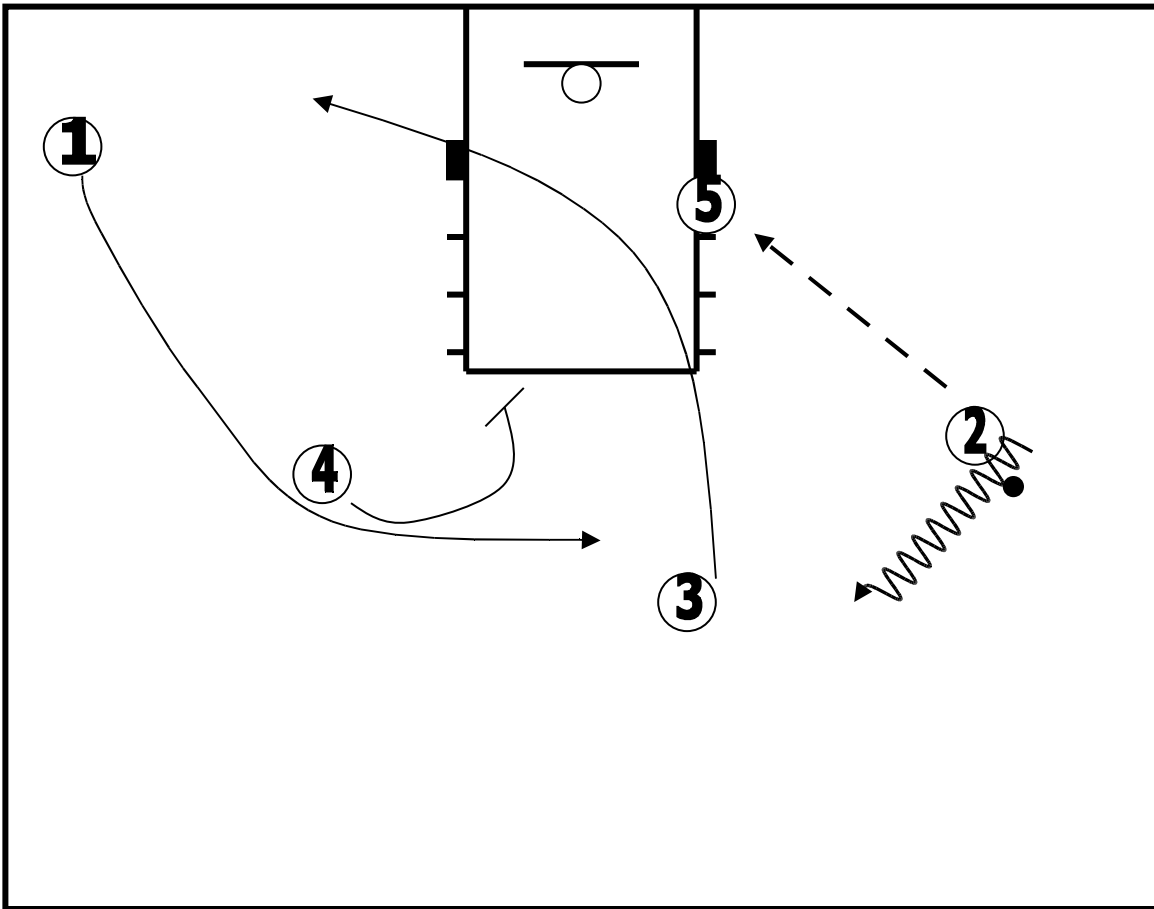

“Orange” option to “Low” series

If defense takes away post isolation by 5 and 3 being denied, 2 dribbles at 3  
–3 back cuts to fill opposite corner

4 screens for 1 and we are now in a “Low” series with 5 occupying the low post

### Part Three Side/ Shuffle Cut Series to top of Key series

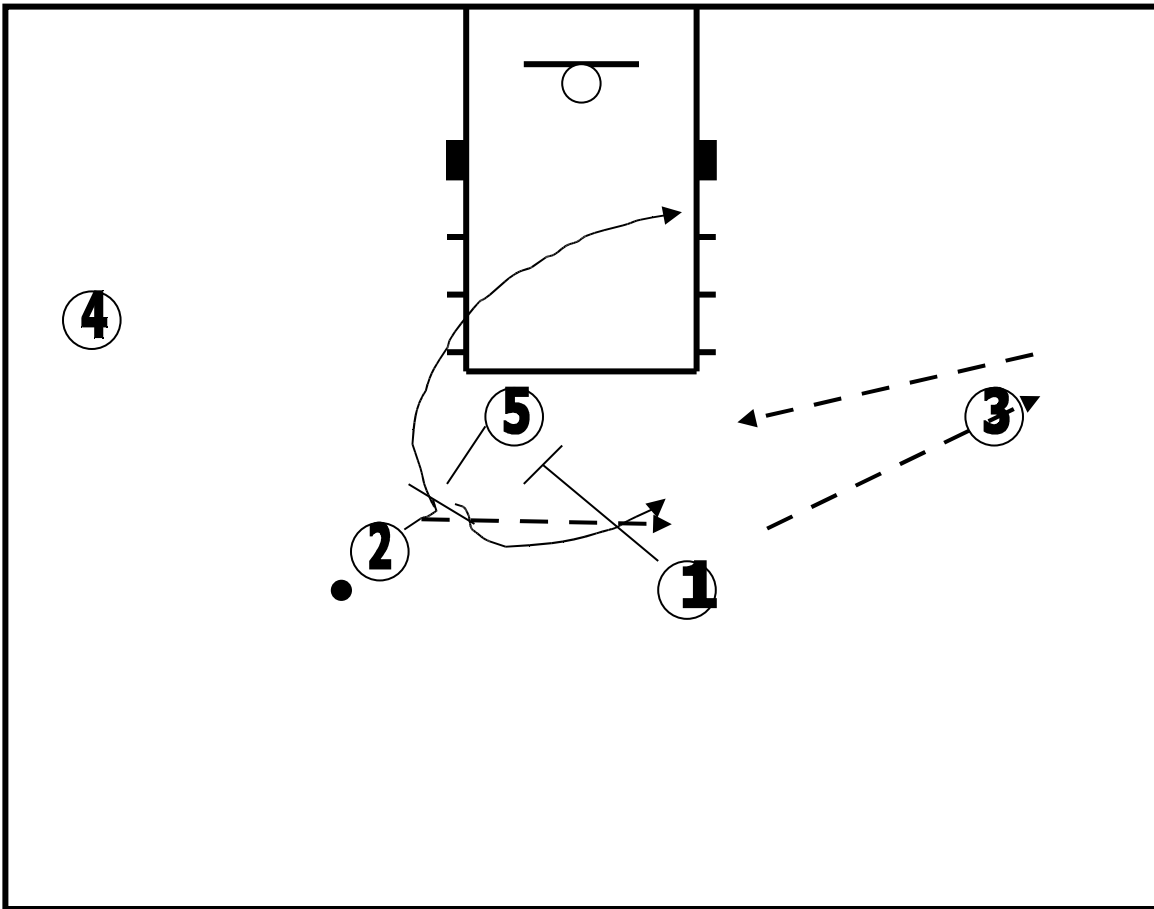

“Blue option” out of side/shuffle series

This action offers an outstanding counter if 5’s defender is giving deep help on the shuffle cut

After 2 cuts off 5, 1 screens for 5 for an open jump shot.

### Part Three Side/ Shuffle Cut Series to top of Key series

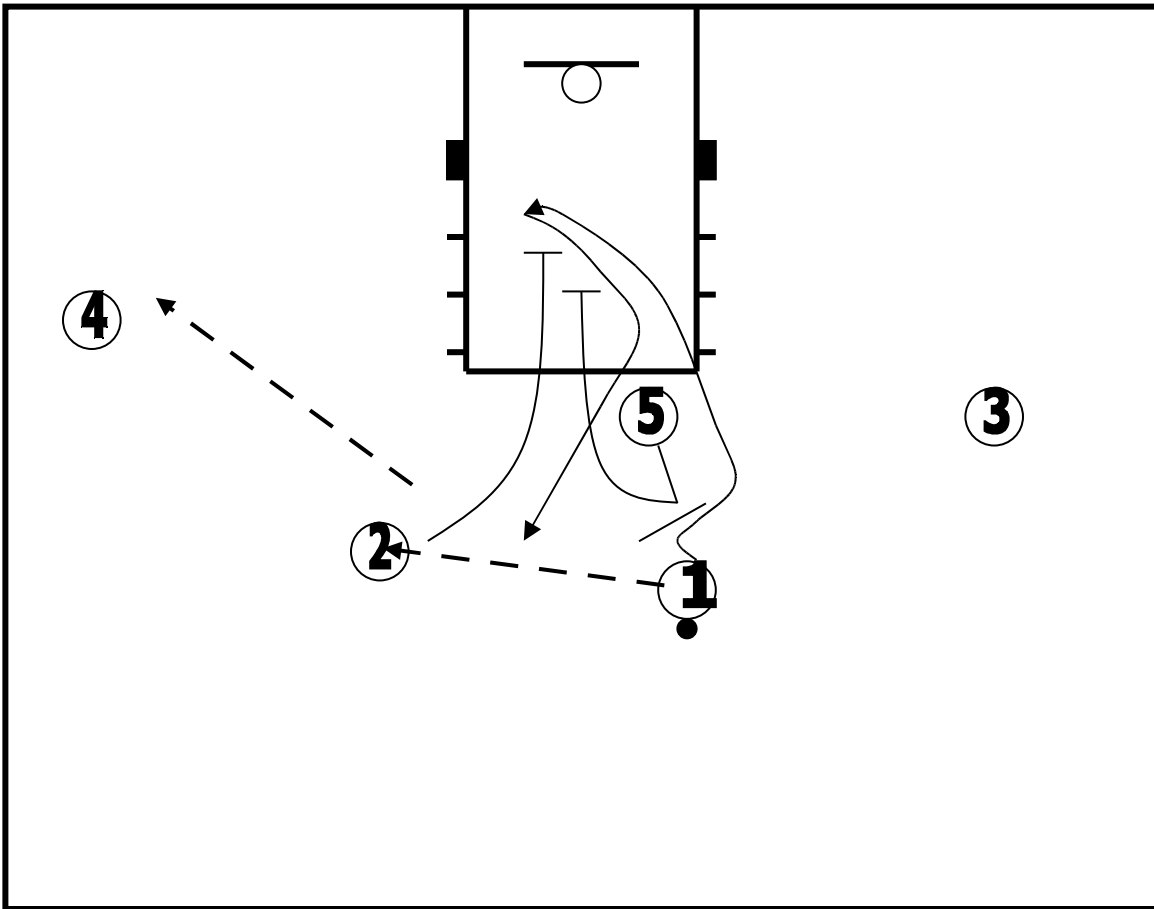

“White” option out of “Side/Shuffle” series

This option works great when defenders begin to anticipate the shuffle cut by their offensive player

Ball has been swung to 4 and 1 cuts off 5

1 now comes off double staggered screen from 2 and 5 for a jump shot opportunity



## Part 4 additional options

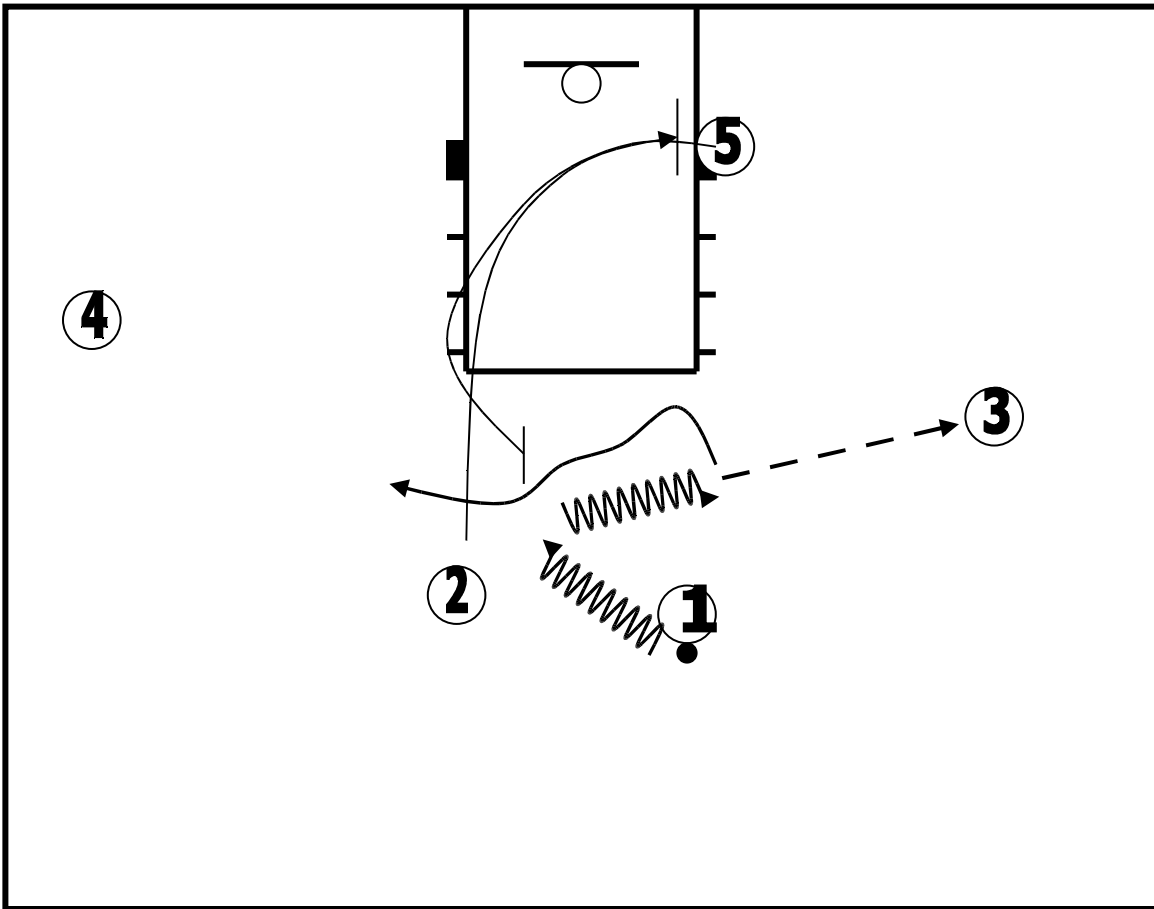

- “Additional scoring Options”: “Rocket” option  
1 dribbles hard at 2, 2 cuts through screening for 5  
5 pops to high post elbow  
1 spins away from 5 and passes to 3  
1 gets a flare screen from 5

Part 4 additional options

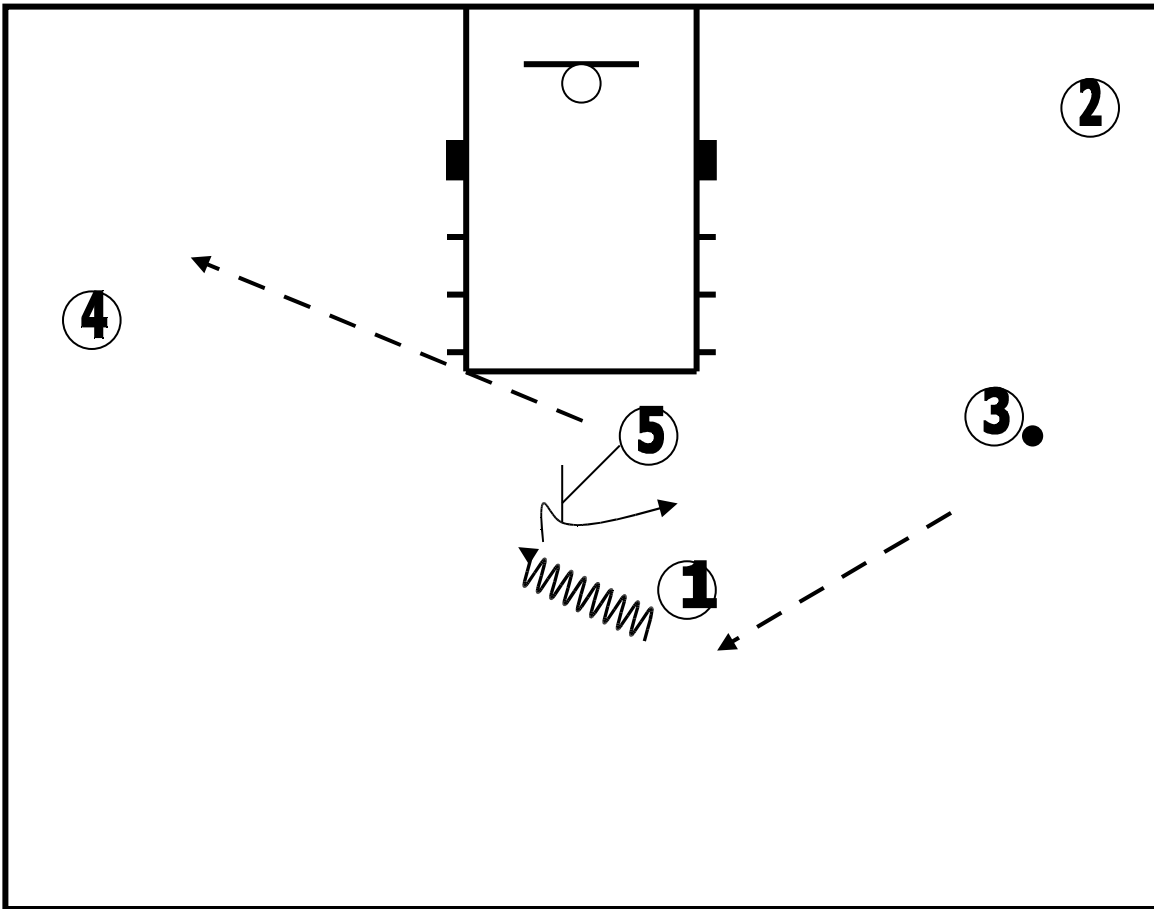

“Additional scoring Options”: “Rocket” option

1 looks for jumper off 5’s flare screen

1 has an option: 1 can swing to 4 and get another flare from 5 looking for a jump shot.

## Part 4 additional options

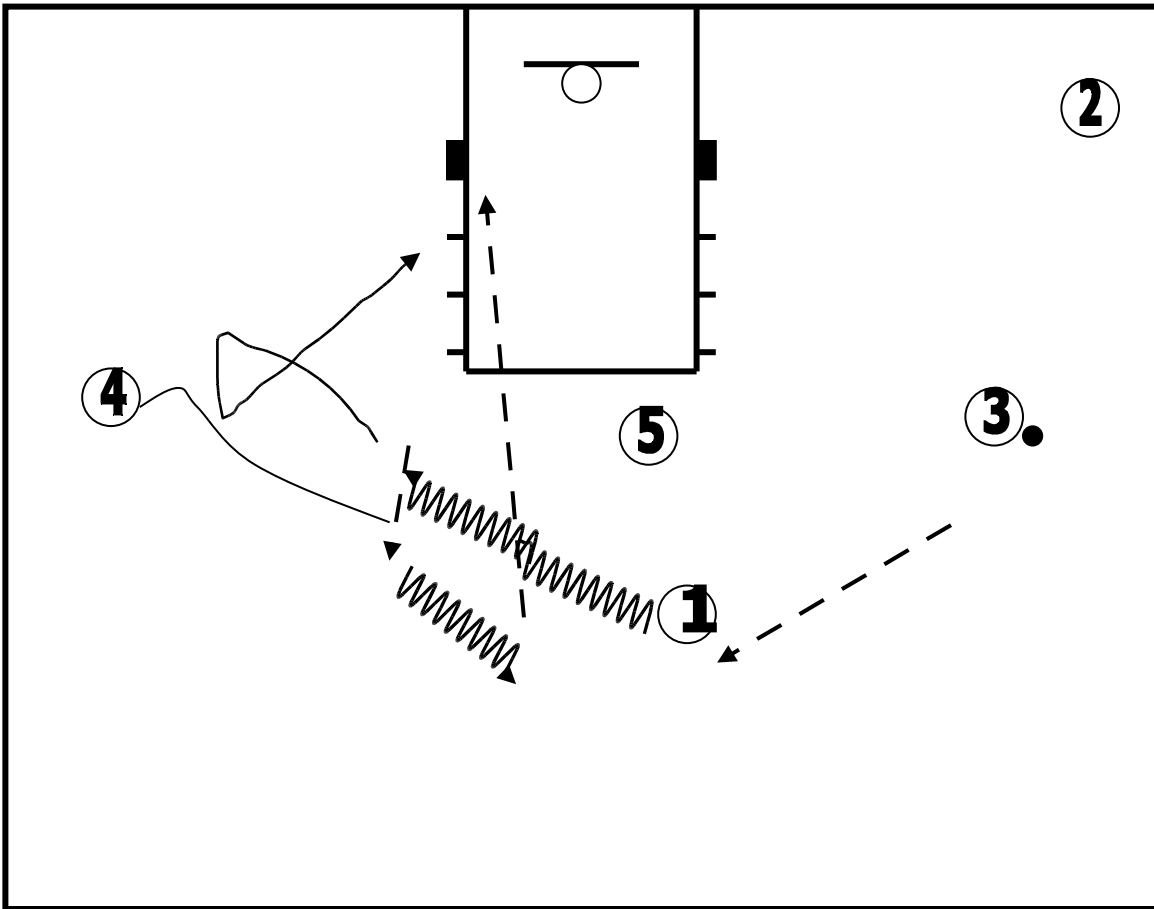

“Additional scoring Options”: “Rocket” option

The next option 1 has is to give dribble handoff to 4

4 takes two dribbles, jump stops, reverse pivots and passes to 1 on a back cut.

### Part 4 additional options

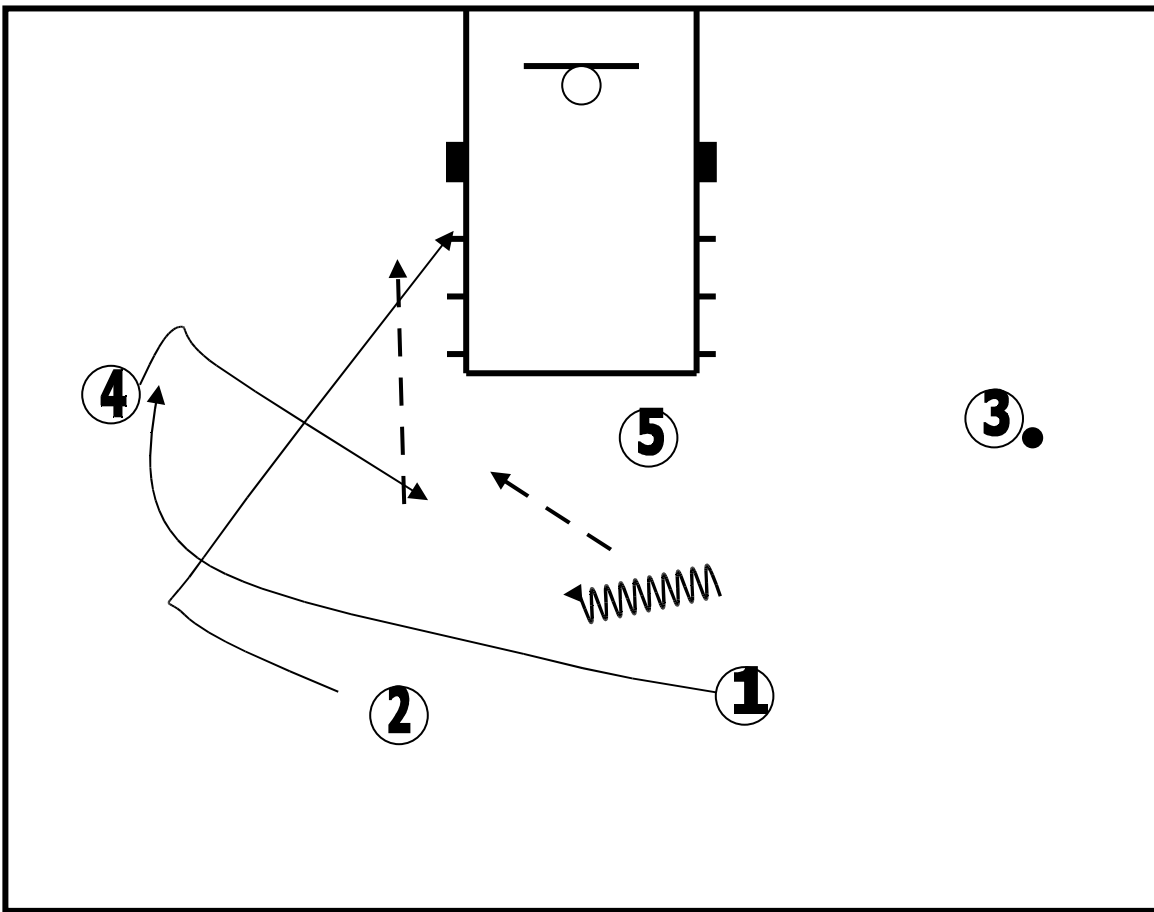

“Additional scoring Options”: “Spread” option

1 passes to 4 after dribbling to middle

on the flight of the pass, 2 cuts backdoor looking for a pass from 4.

1 fills to the wing spot.

Part 4 additional options

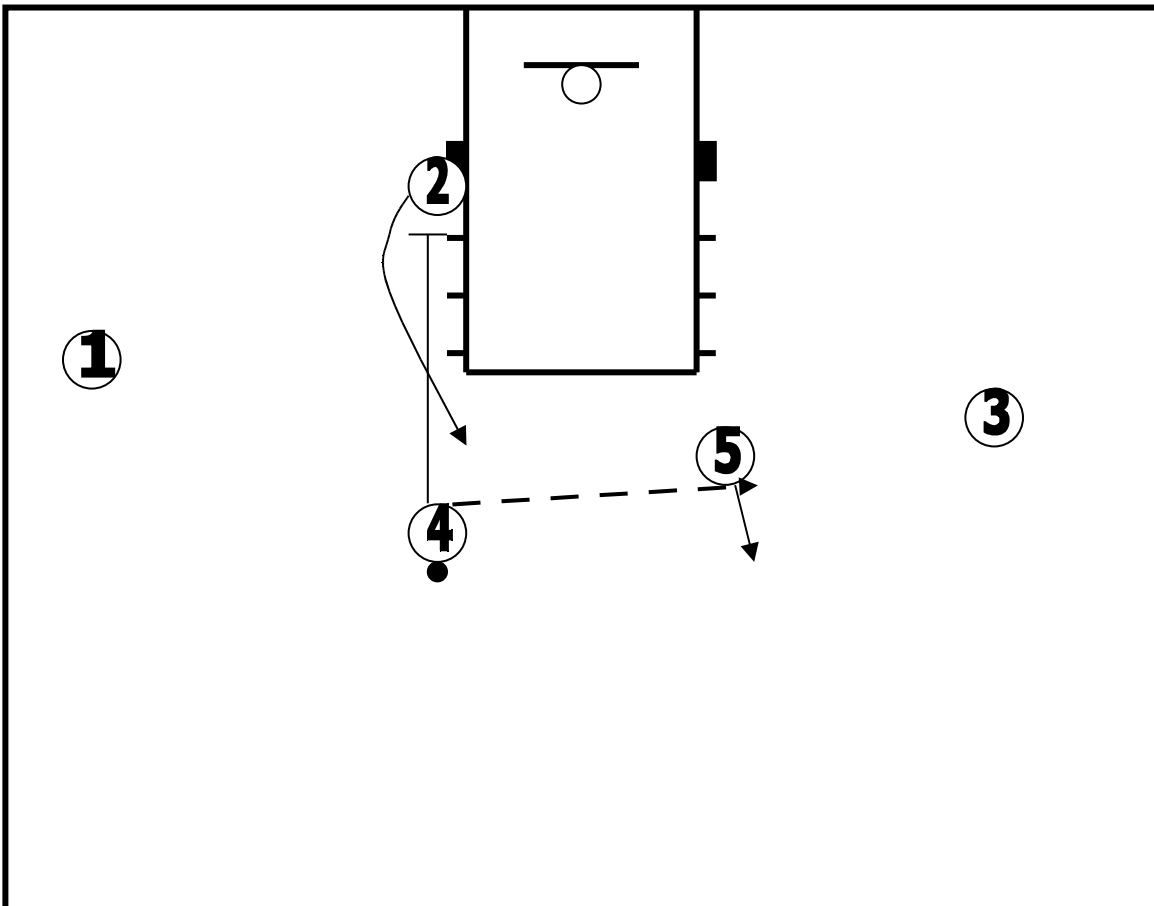

“Additional scoring Options”: “Spread” option  
4 passes to 5 if 2 is not open on the back door  
4 then down screens for 2

#### Part 4 Additional Options

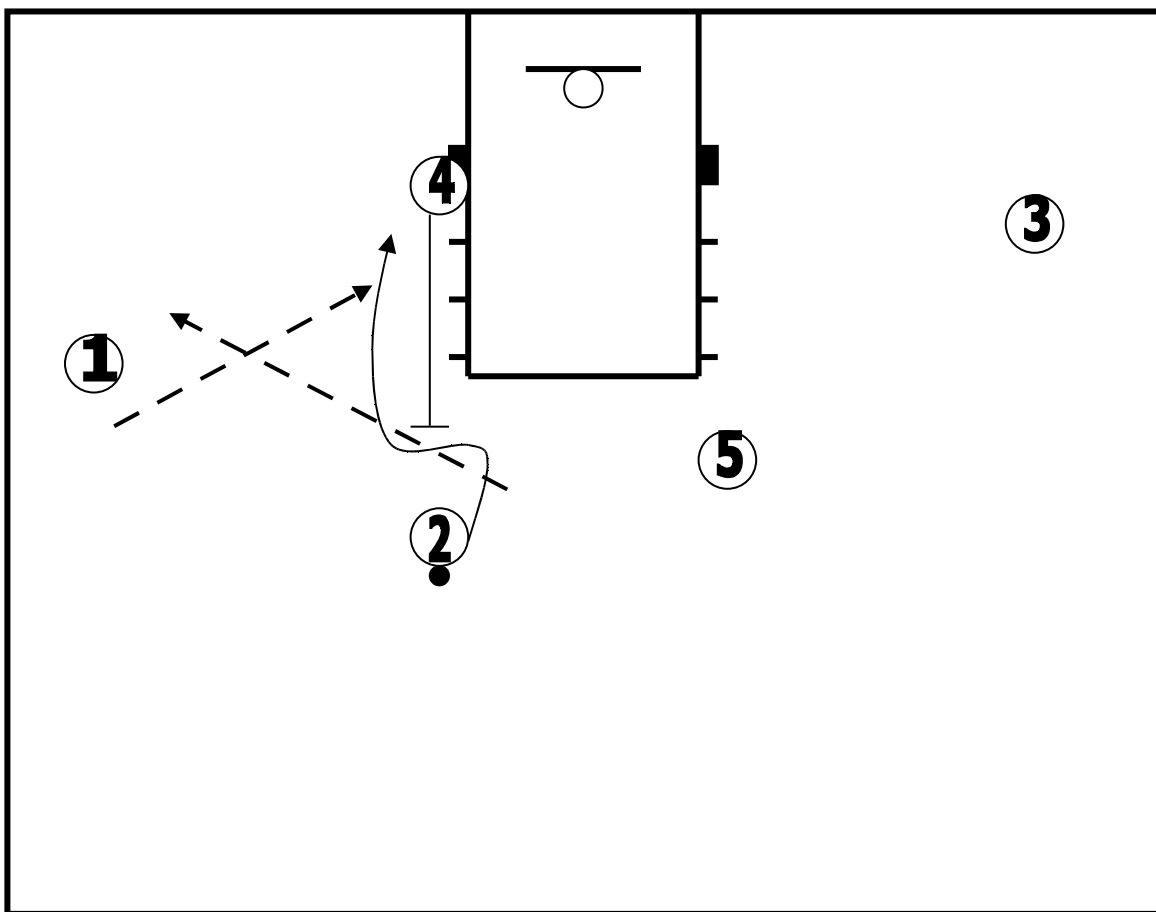

“Additional scoring Options”: “Spread” option  
5 reverses the ball to 2. 2 passes to 1  
4 now up screens for 2 for an isolation in the post

#### Part 4 Additional Options

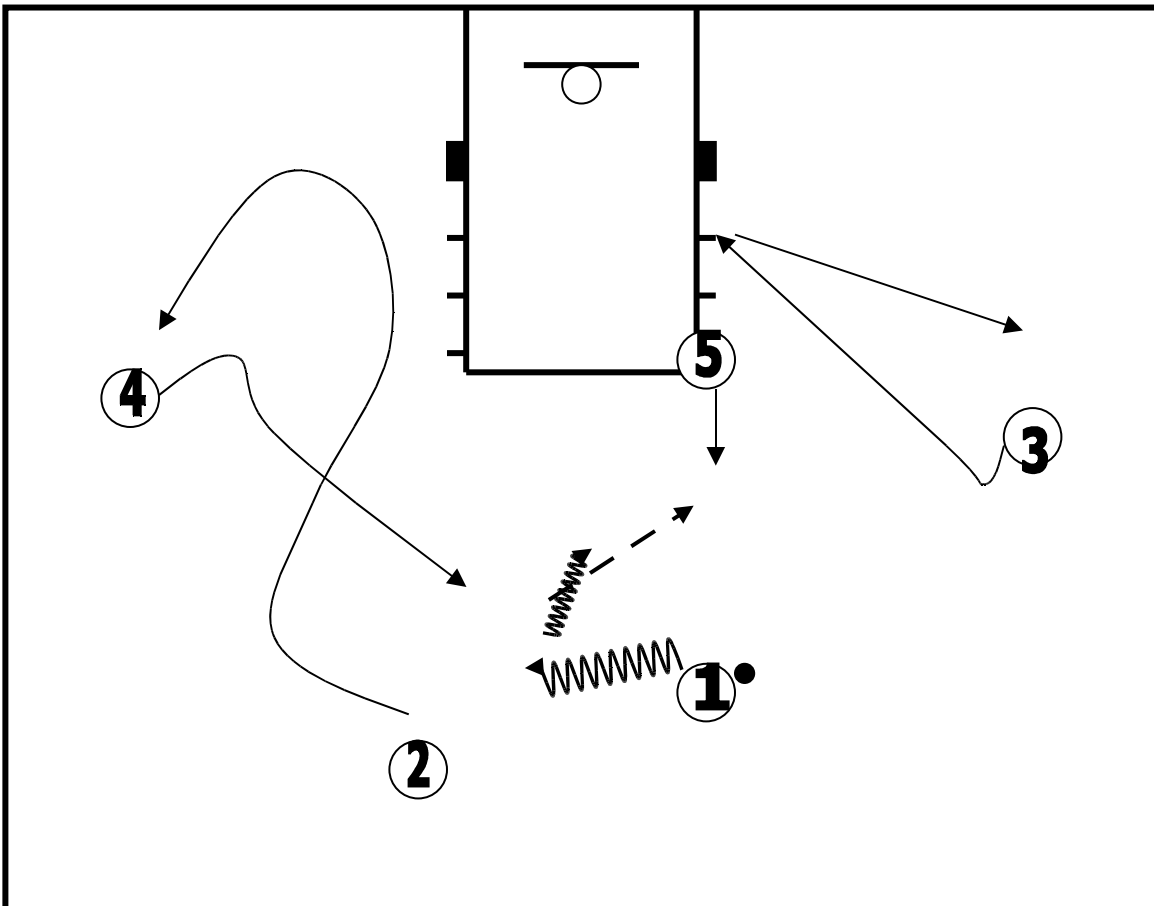

“Additional scoring Options”: “Cardinal” option

Players are in Side/Shuffle alignment

1 dribbles at 4 and spins back and passes to 5

5 looks to pass to 3 on a back door

2 has faded to weak side corner

If 3 is not open, he walks back outside to the 3-pt arc.

## Part 4 Additional Options

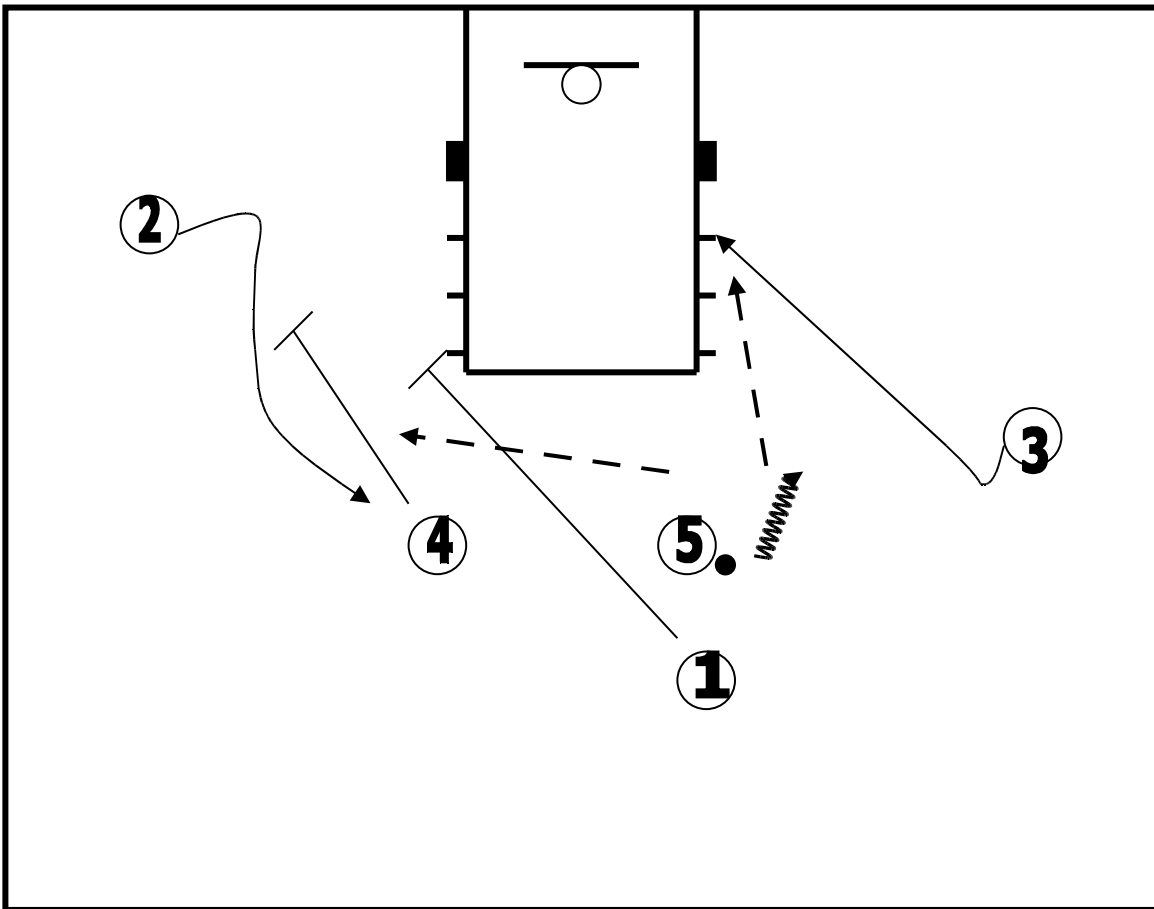

“Additional scoring Options”: “Cardinal” option

5 has two options now, as 3 was not open on the back door. He can pass to 2 coming off a double screen from 1 and 4 or he can look to pass to 3 after dribbling at him to freeze 3’s defender.



#### Part 4 Additional Options

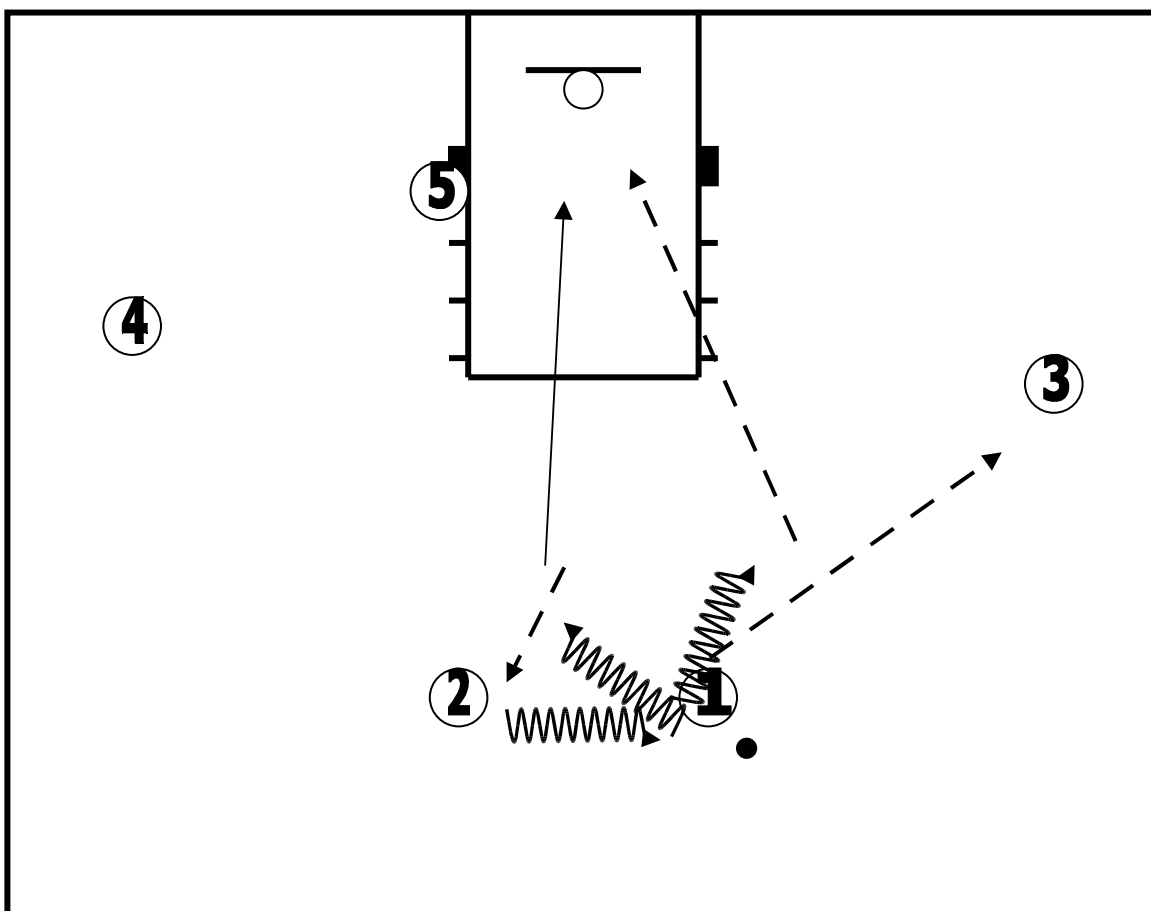

“Additional scoring Options”: “Astro” option  
1 dribbles at 2 and gives him a hand off  
2 looks to pass to 1 on a back cut  
if 1 is not open, 2 passes to 3.

#### Part 4 Additional Options

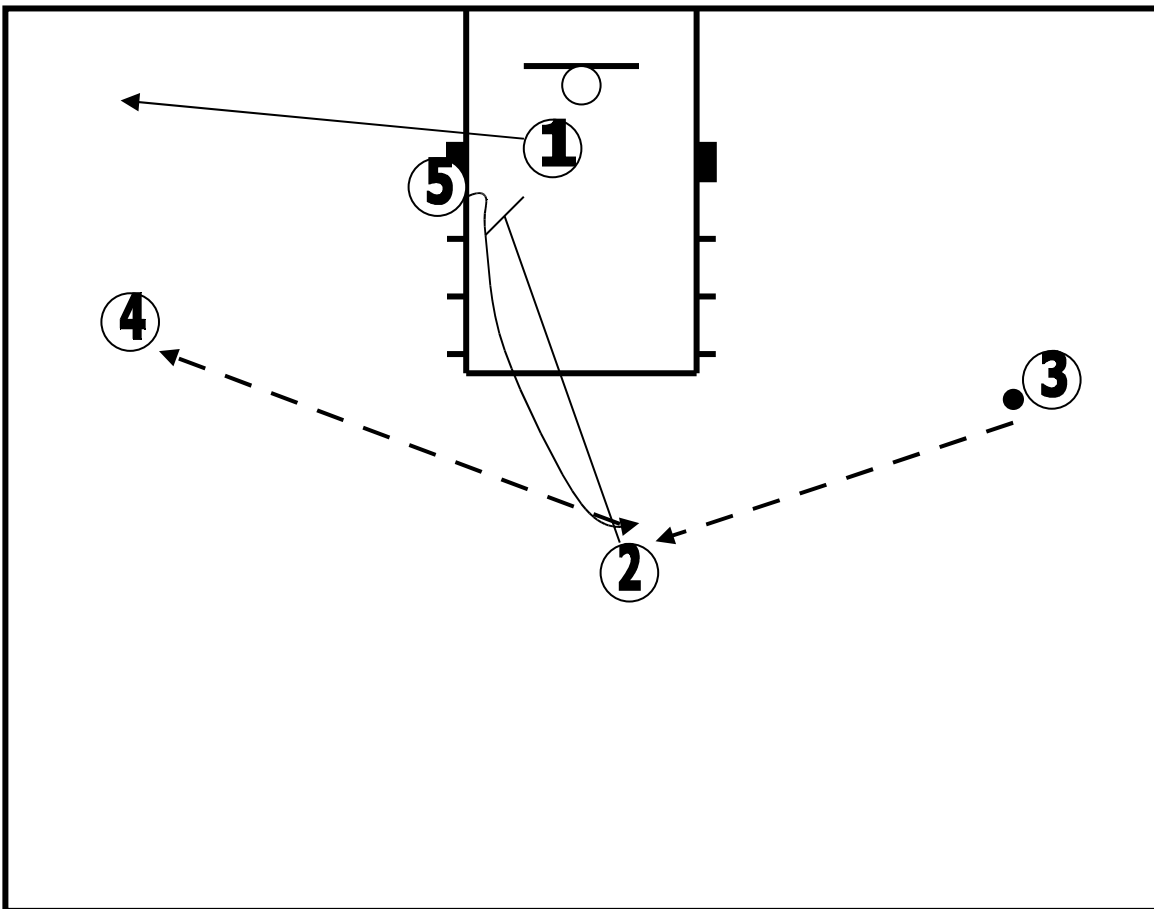

“Additional scoring Options”: “Astro” option

1 was not open so 2 has passed to 3

2 Down screens for 5

5 gets pass from 3 then reverses to 4

### Part 4 Additional Options

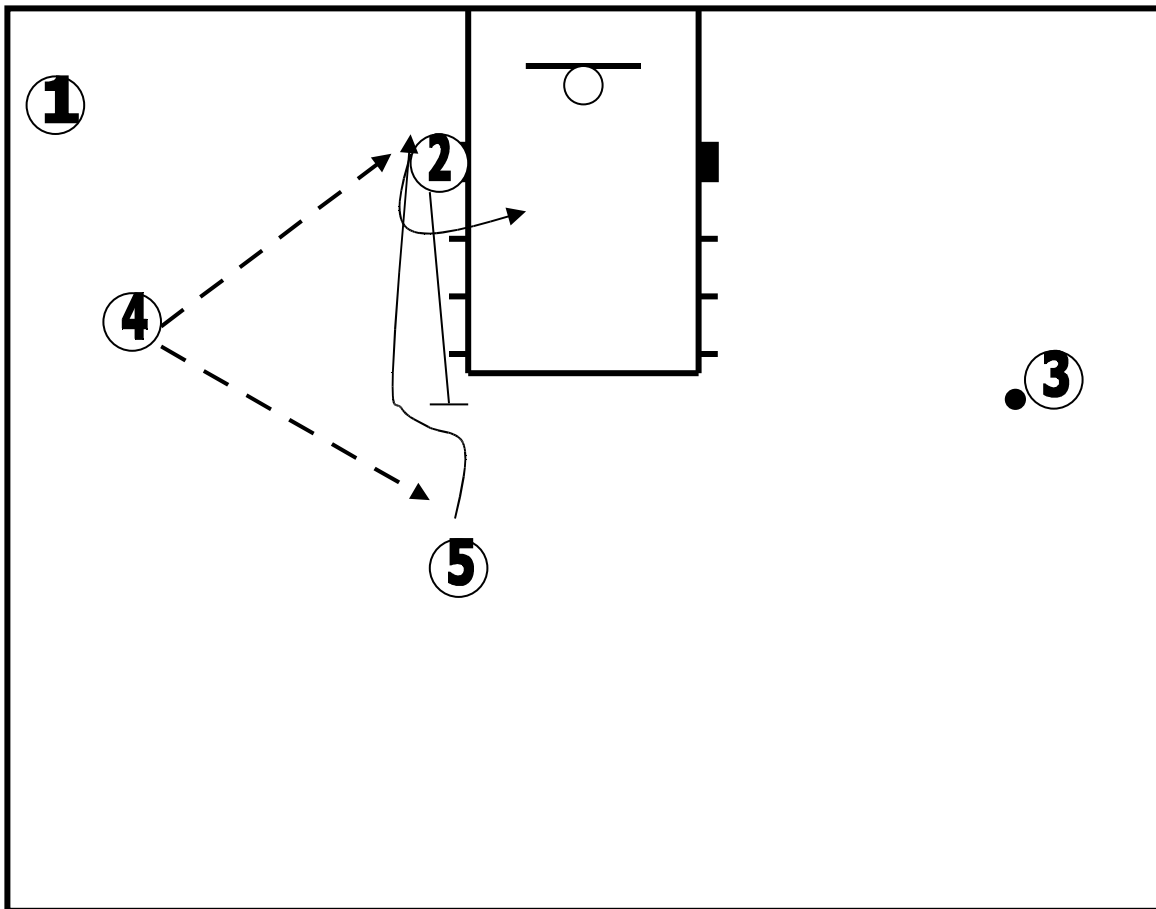

“Additional scoring Options”: “Astro” option

4 has the ball

After 5 passes to 4, 2 sets a back screen for 5 for post isolation

If 5 is not open immediately, 4 can pass to 2 on a step out for a jumper or pass to 5 on a duck- in

### Part 5 Special Sets

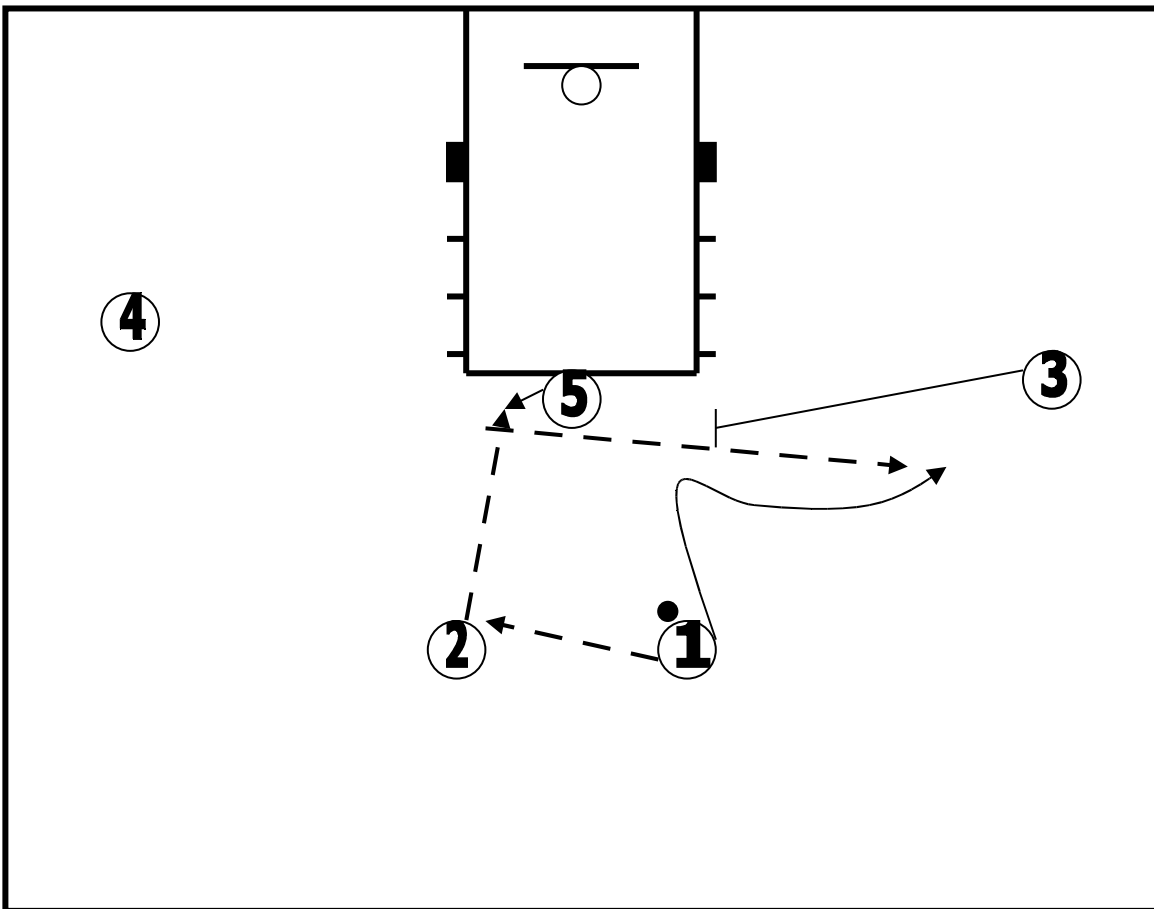

“High Series”: Flare for 3pt shoot

Players are in a 2-3 alignment

1 passes to 2, 2 passes to 5 at the high post

on the pass from 2 to 5, 1 cuts in and receives flare screen from 3 for a jump shot

## Part 5 Special Sets

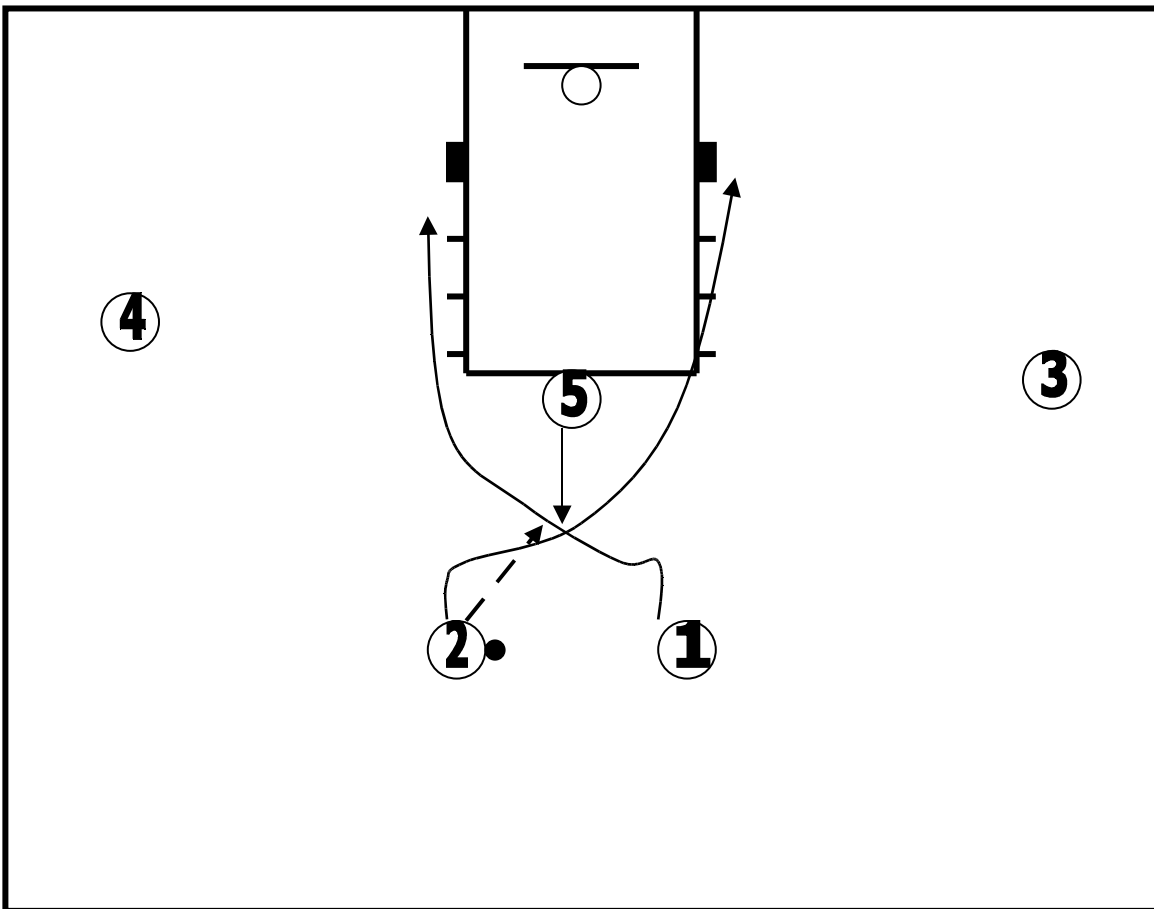

Special Set: Scissors" (A)

Players are in a 2-3 alignment

2 passes to 5, 2 and 1 then will scissor off 5 for a hand off of open, 2 goes first

5 reverses pivots and squares to the basket

## Part 5 Special Sets

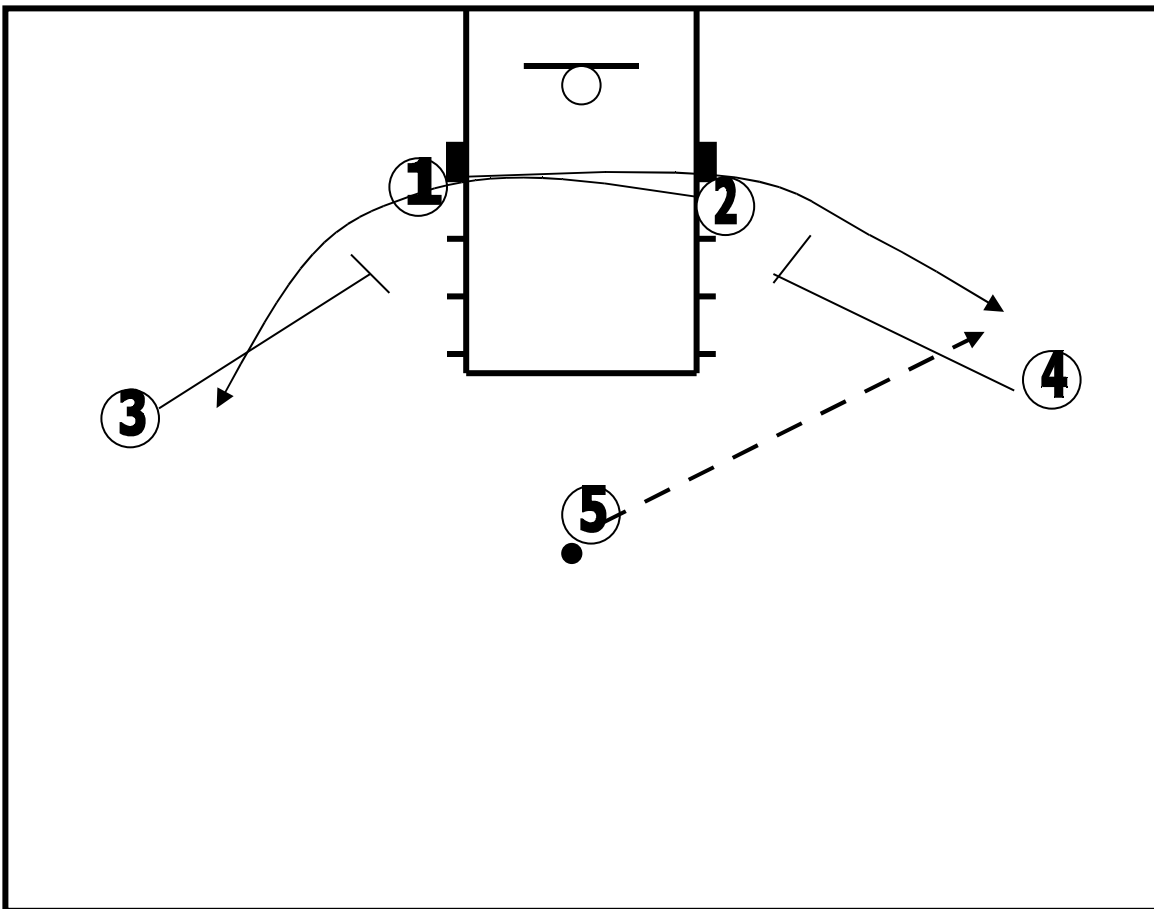

### Special Set: Scissors" (B)

1, 2 now criss-cross and receive down screens from 3 and 4  
5 looks to pass to 1 and 2 for a jump shot

### Part 5 Special Sets

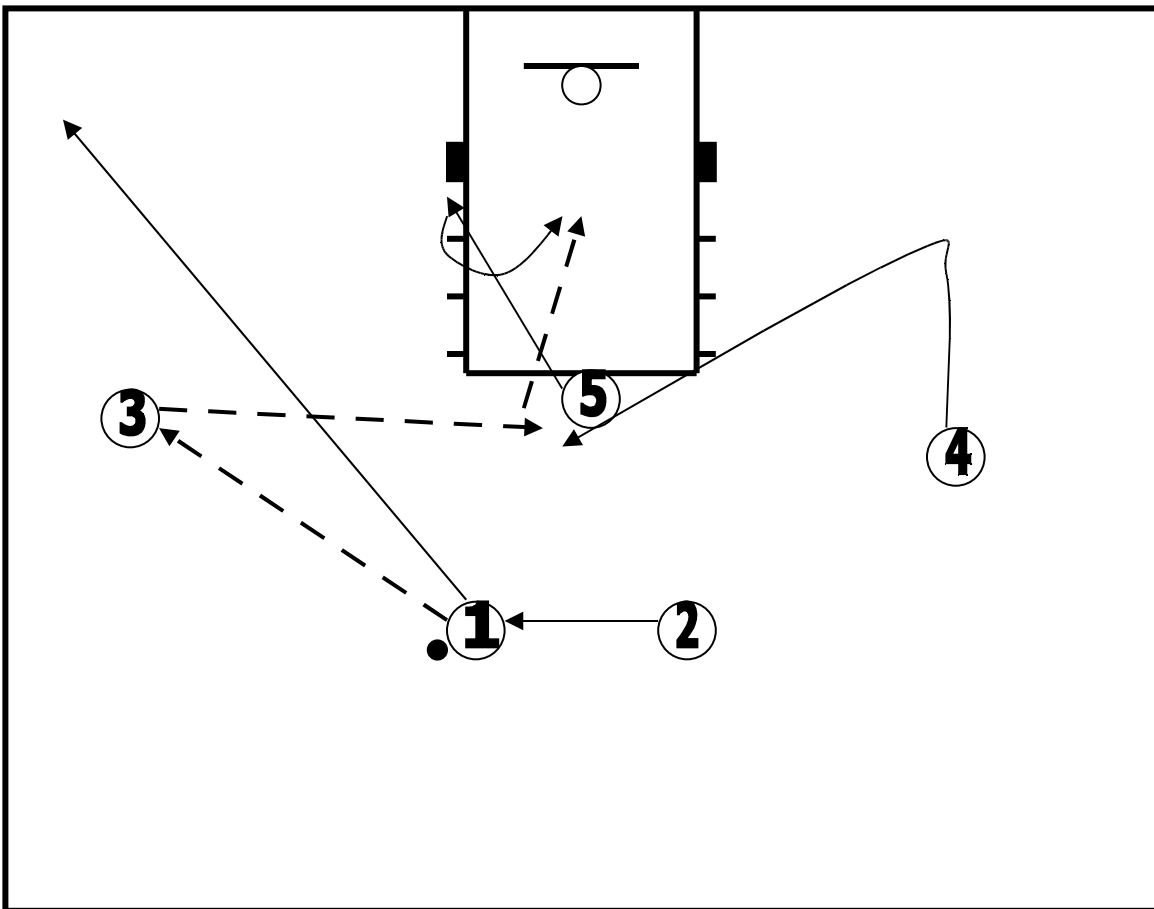

“Special Sets”: ISO

Players are in a 2-3

1 passes to 3 on the wing, 1 then cuts hard to the corner

5 dives hard to the block

4 V cuts hard to fill the high post area, receives ball from 3

2 fills 1 's spot  
4 looks to pass to 5 on the duck-in

### Part 5 Special Sets

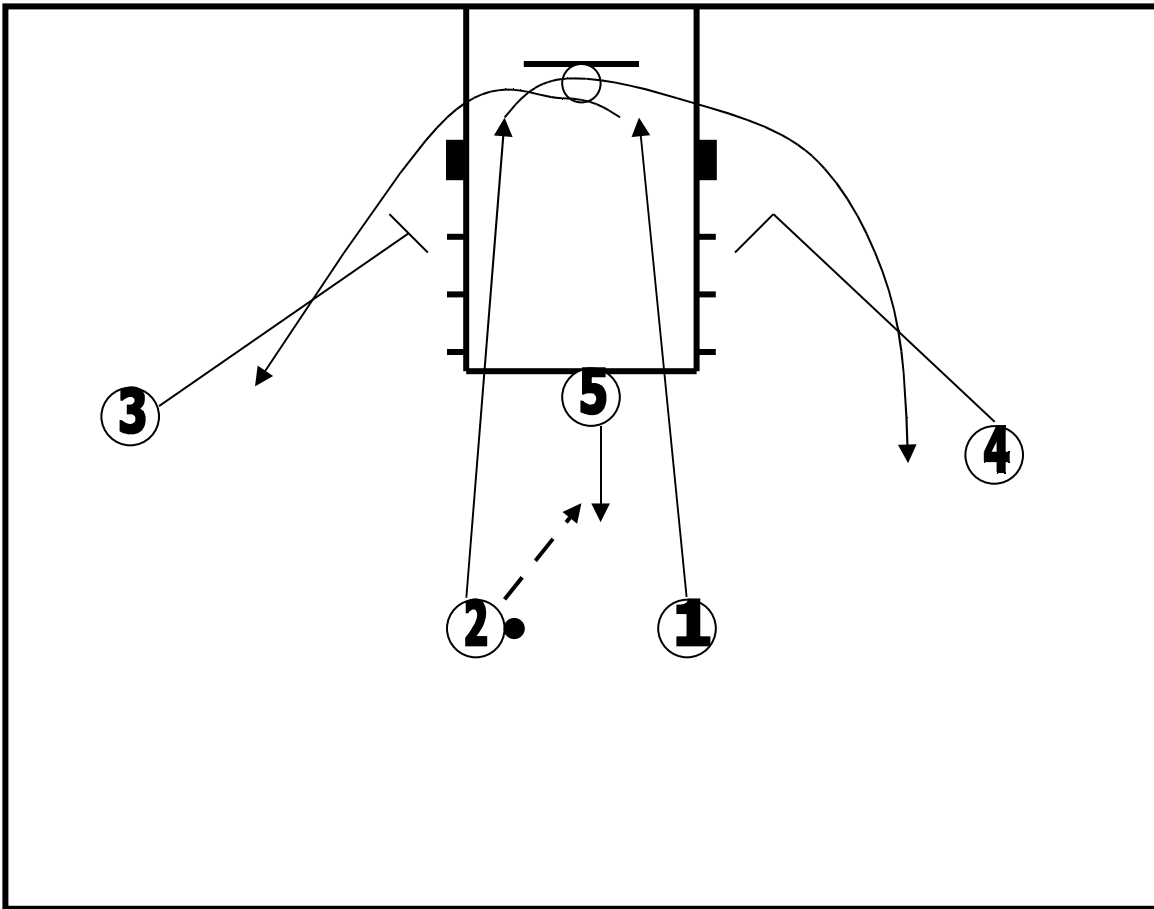

Special Set: “ Triangle” (A)  
Players are in a 2-3 set  
2 passes to 5 on a step out  
1 and 2 basket cut hard and criss-cross,  
getting screens from 3 and 4



### Part 5 Special Sets

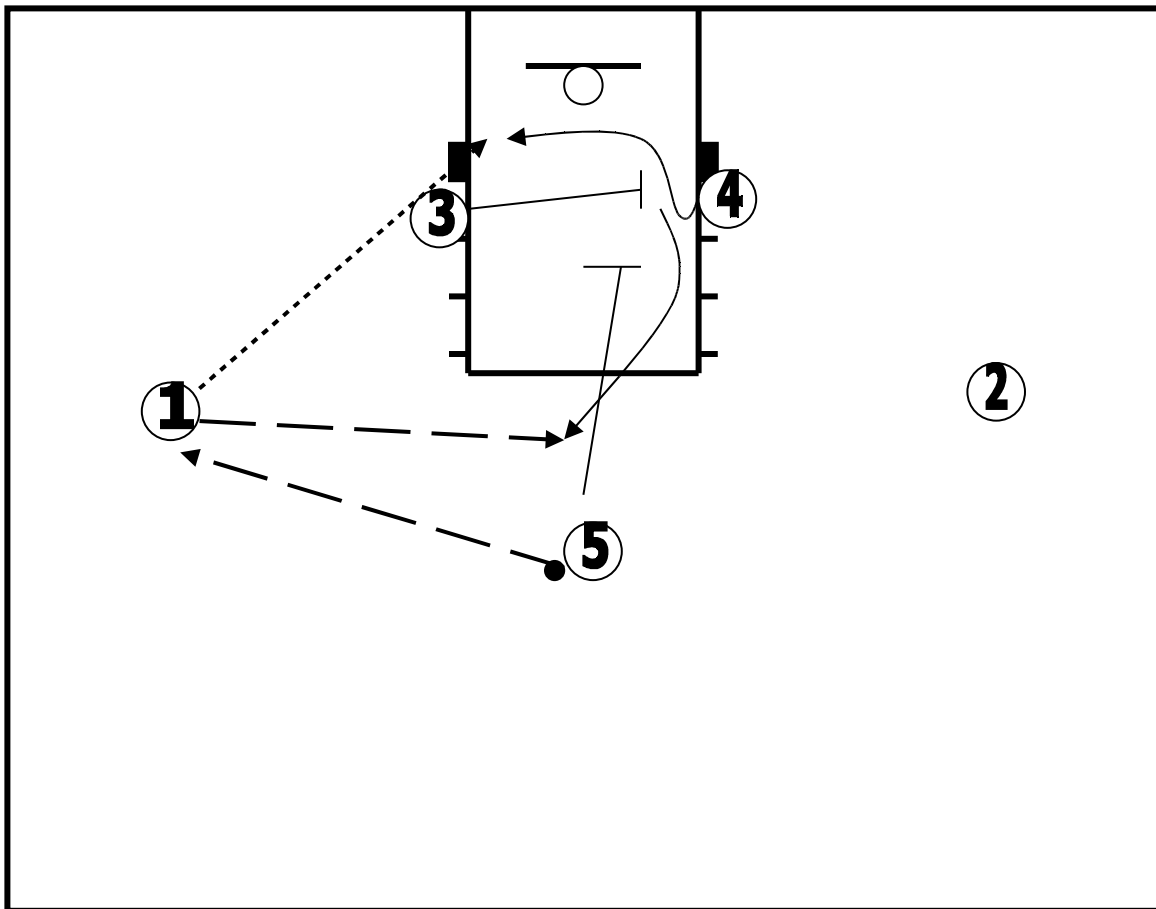

Special Set: “ Triangle” (B)

5 passes to 1, 3 now cross screens for 4

1 looks to pass to 4 for a lay up

5 then screens for 3 looking FT line jump shot

### Part 5 Special Sets

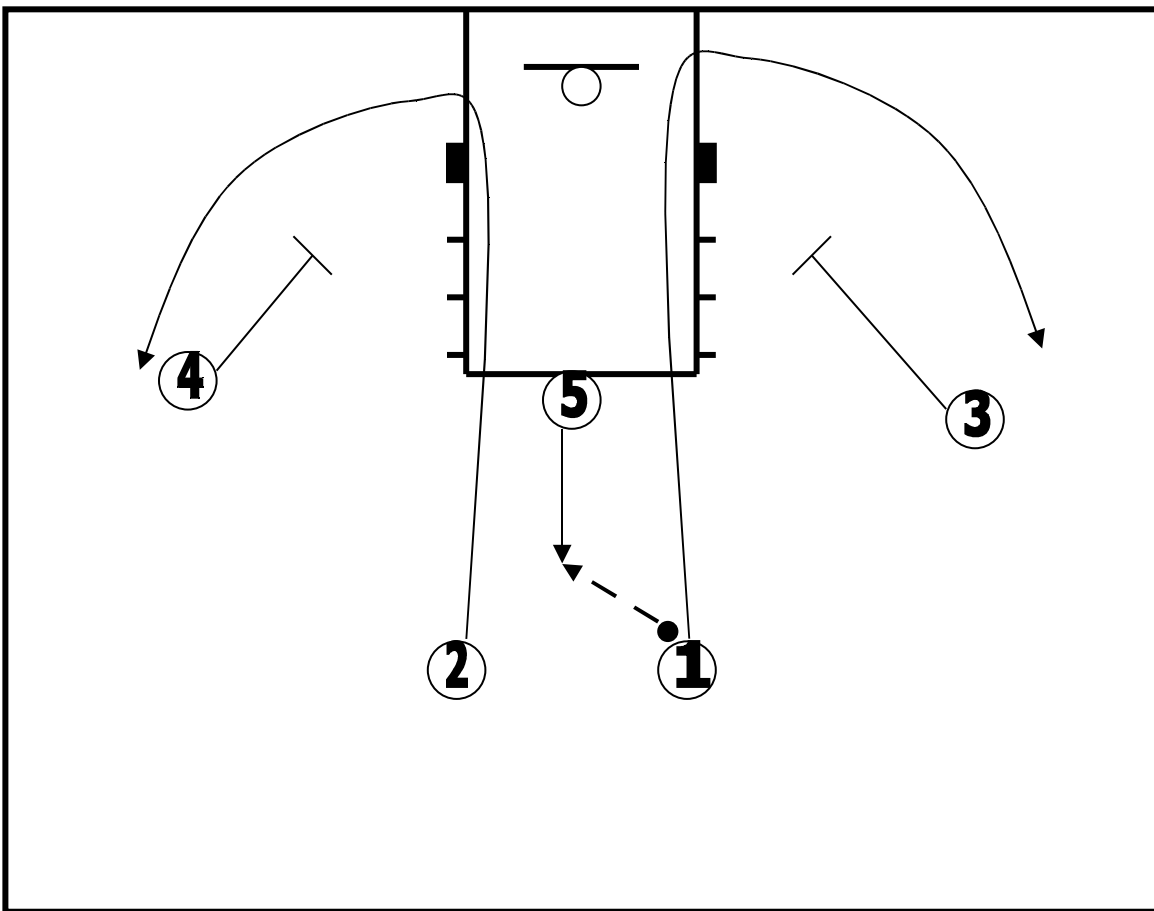

Special Set: "Circle Special" (A)

Players in 2-3 alignment

1 passes to 3, 3 passes to 5 on a step out high

1, 2 are basket cutting, then receiving screens for 3 and 4

### Part 5 Special Sets

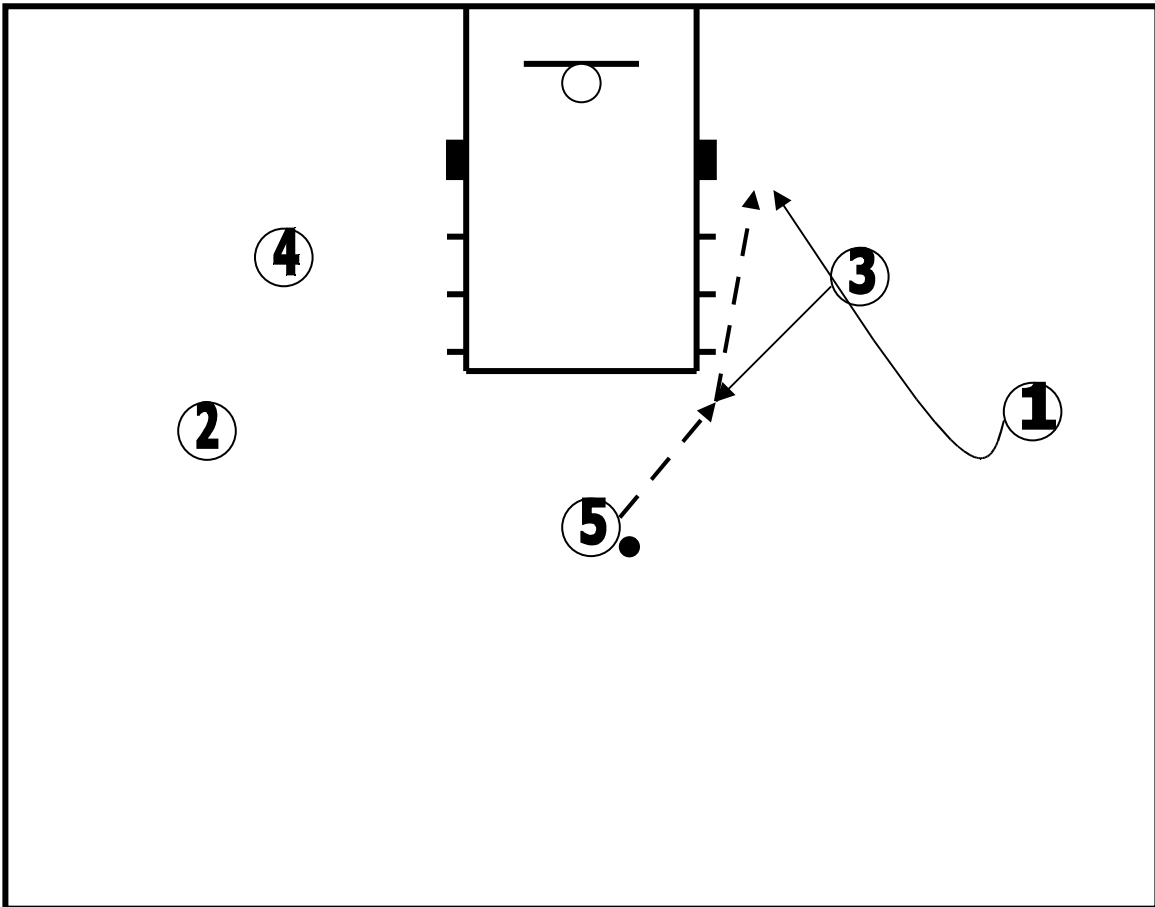

Special Set: “ Circle Special” (B)  
5 passes to 3 or 4 as they flash back to 5 after setting screen  
on the pass , 1 steps high and back doors his man for an easy lay up

Set this play by running "circle" entry

### Part 5 Special Sets

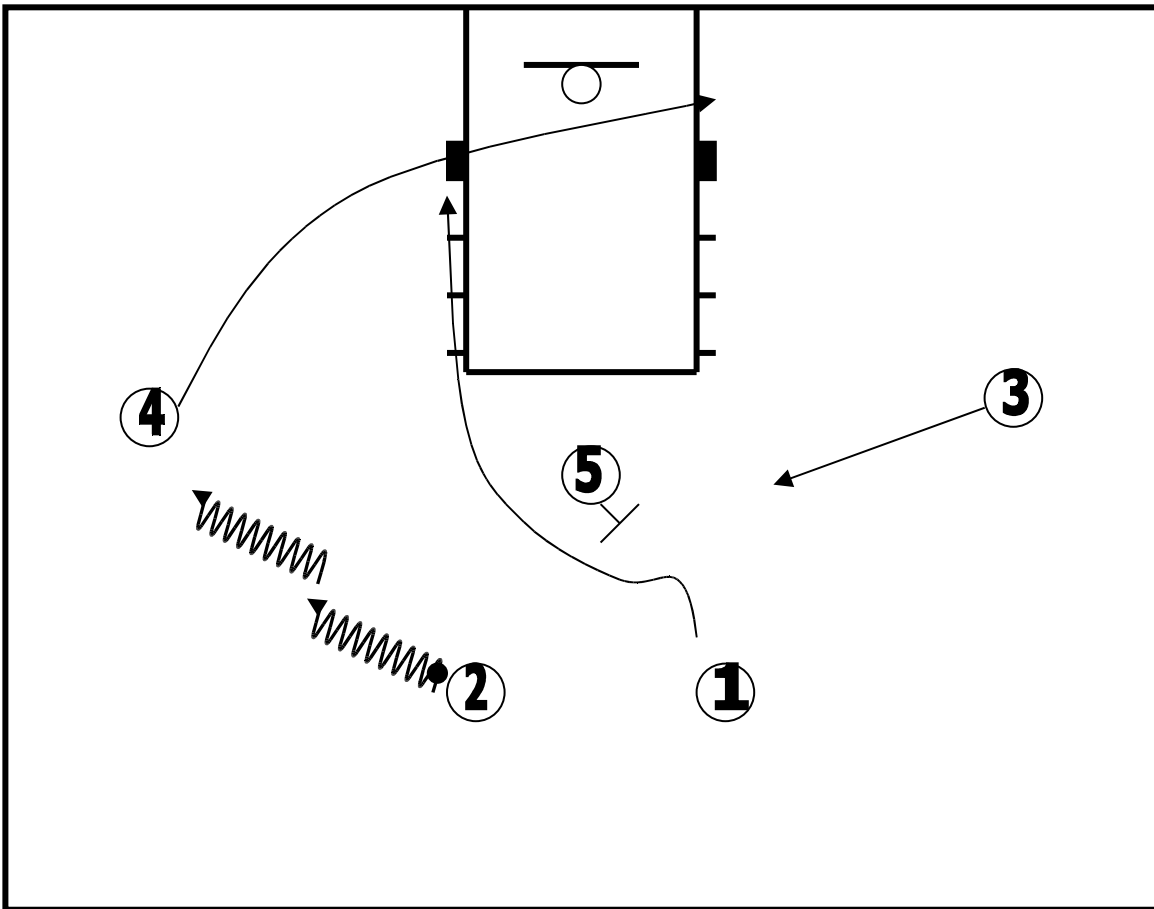

Special Set: "Dribble Entry" (A)  
Players are in a 2-3 alignment  
2 dribbles hard at 4 who back cuts his man to the paint  
At the same time, 1 is coming off back screen from 5 looking for a lay up

### Part 5 Special Sets

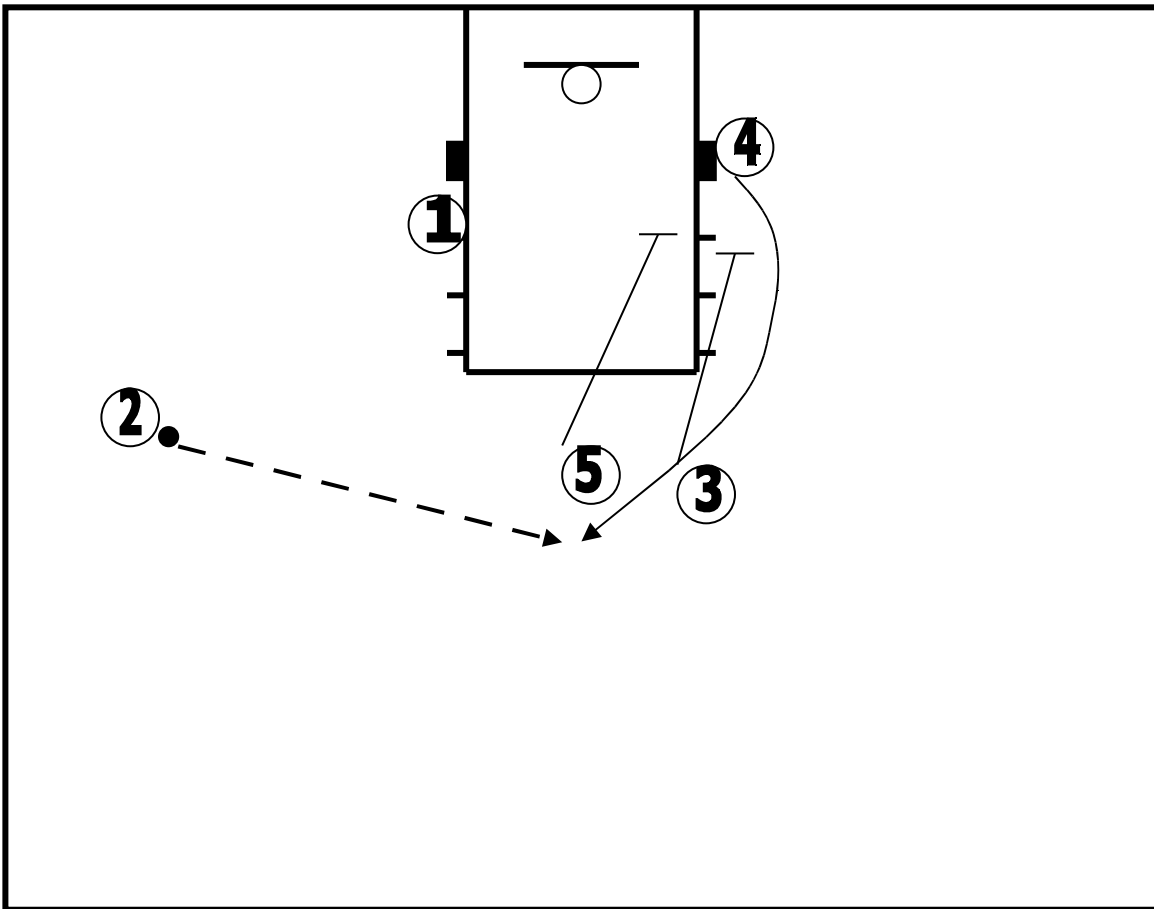

Special Set: "Dribble Entry" (B)

If 1 is not open, 2 can pass to 4 coming off a double staggered screen from 5,3

## Part 5 Special Sets

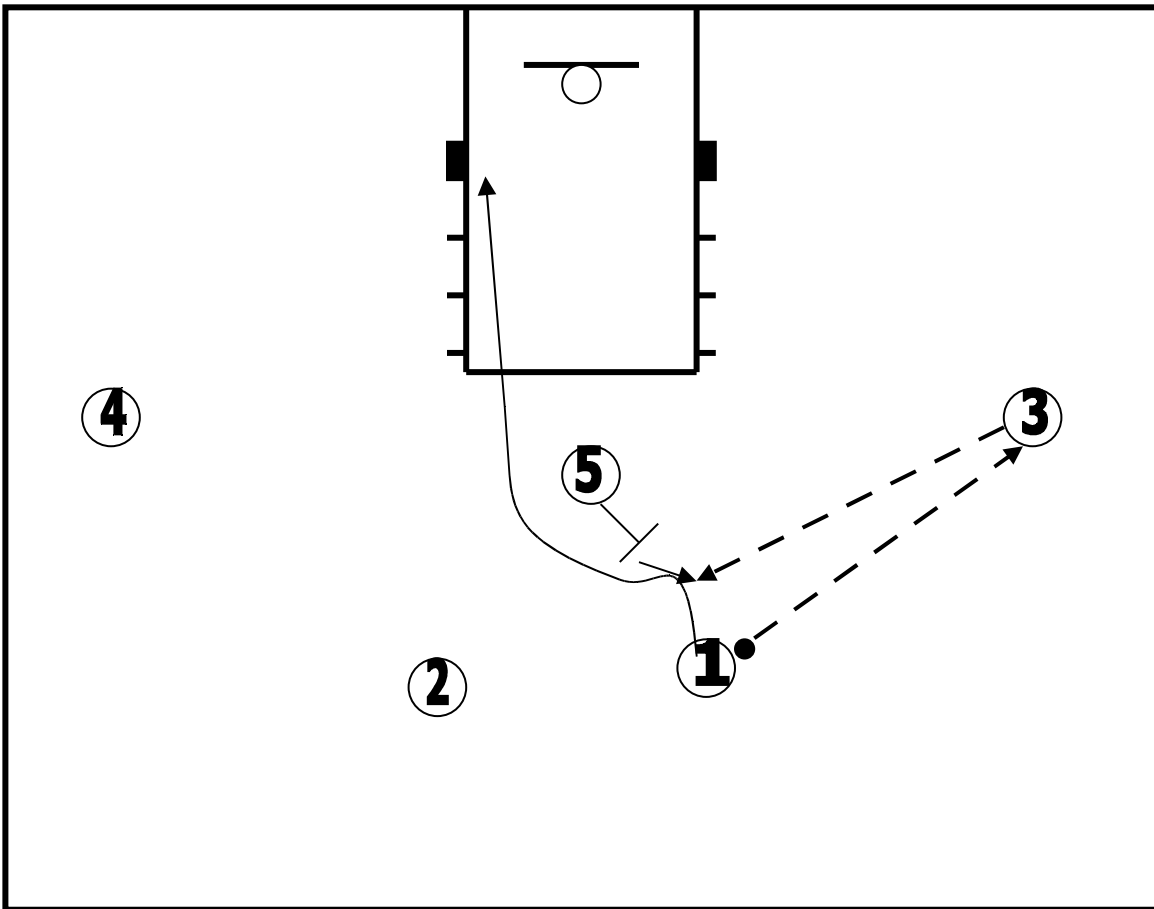

Special Set: "State" (A)

Players are in a 2-3 alignment

1 passes to 3, 5 back picks for 1 looking for a lob pass  
if not open, 5 steps out for reversal of pass from 3.

### Part 5 Special Sets

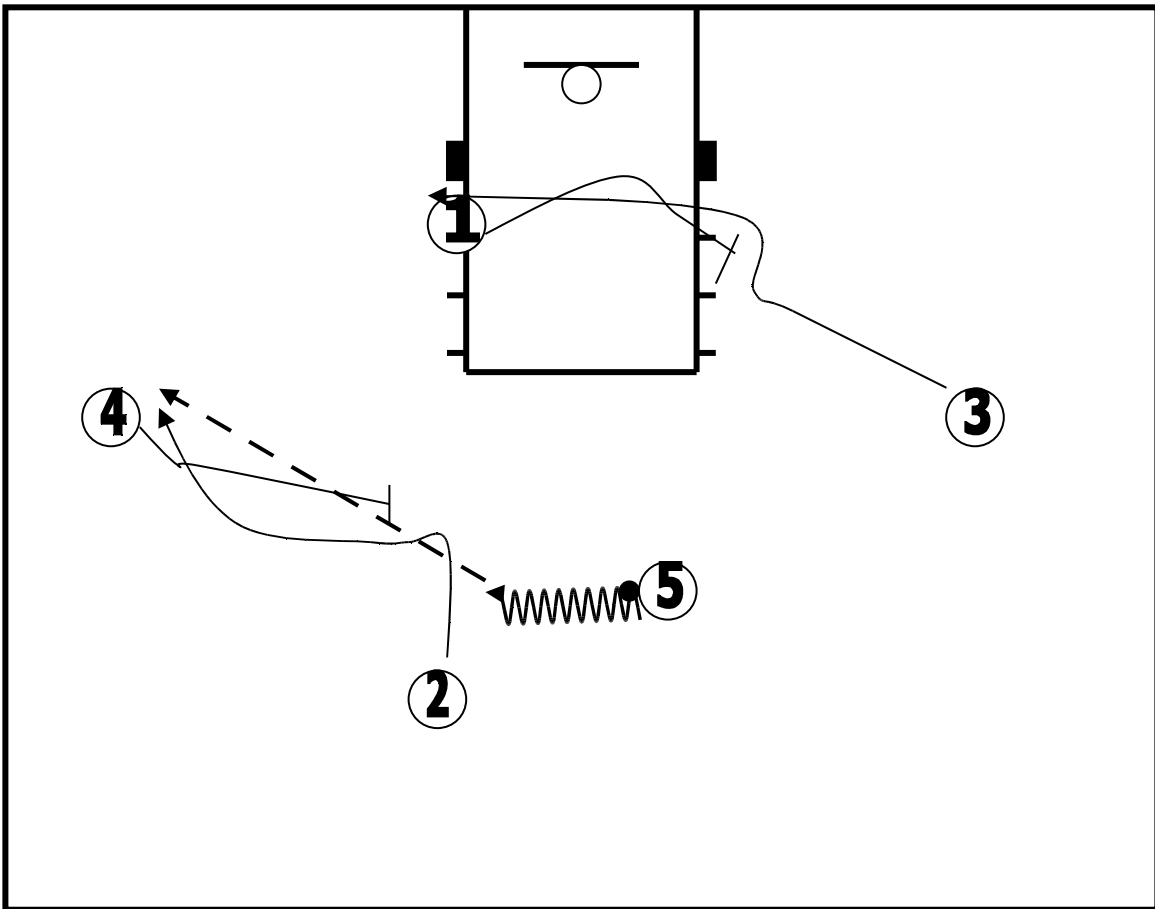

Special Set: "State" (B)  
5 takes two hard dribbles to the left and swings the ball to 2, 2 uses 4's flare screen

At the same time (flight of the ball from 5 to 2) 1 has gone to set a cross screen for 3 looking for a post feed.

### Part 5 Special Sets

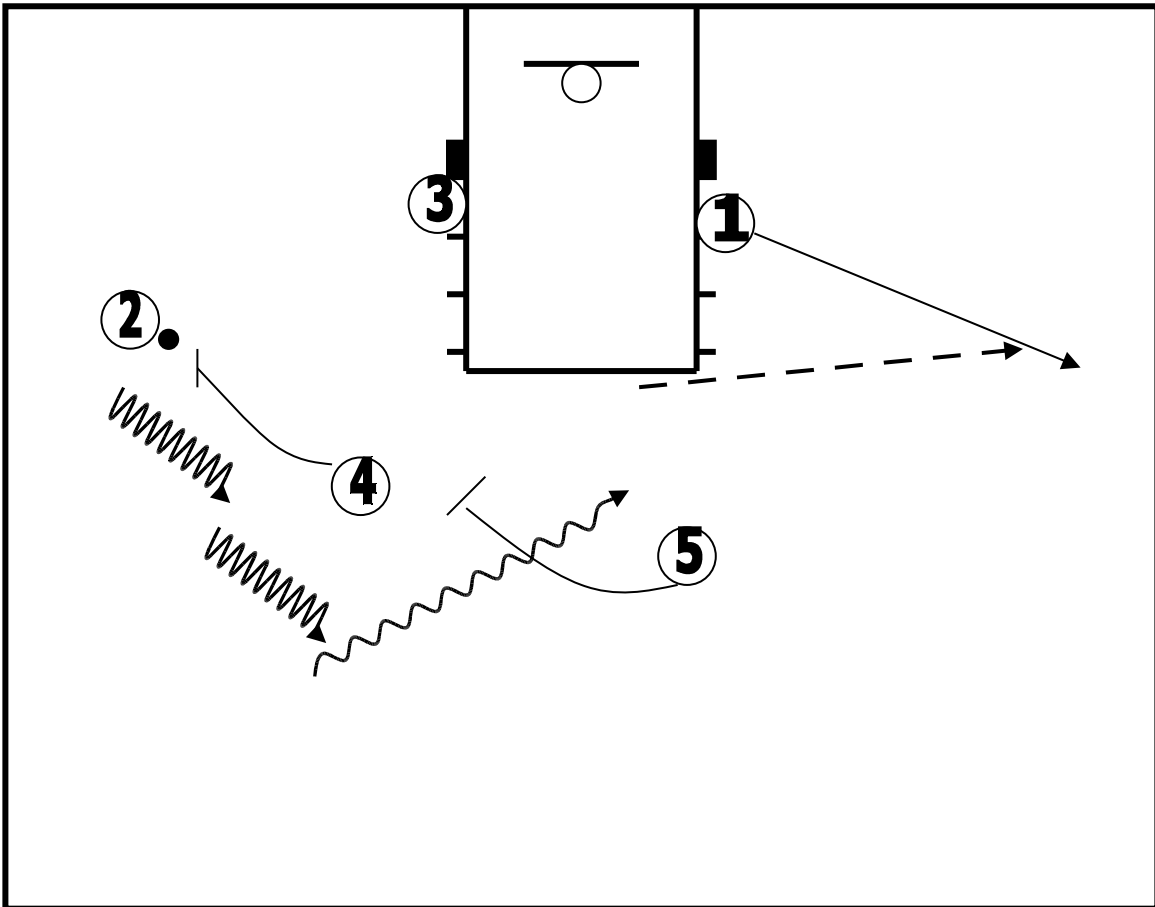

Special Set: "State" (C)



If no shot exists for 2 or 3, then 4 and 5 proceed to set a double staggered ball screen for 2 who looks to create  
1 drifts to the corner spotting up for a jumper.

### Part 5 Special Sets

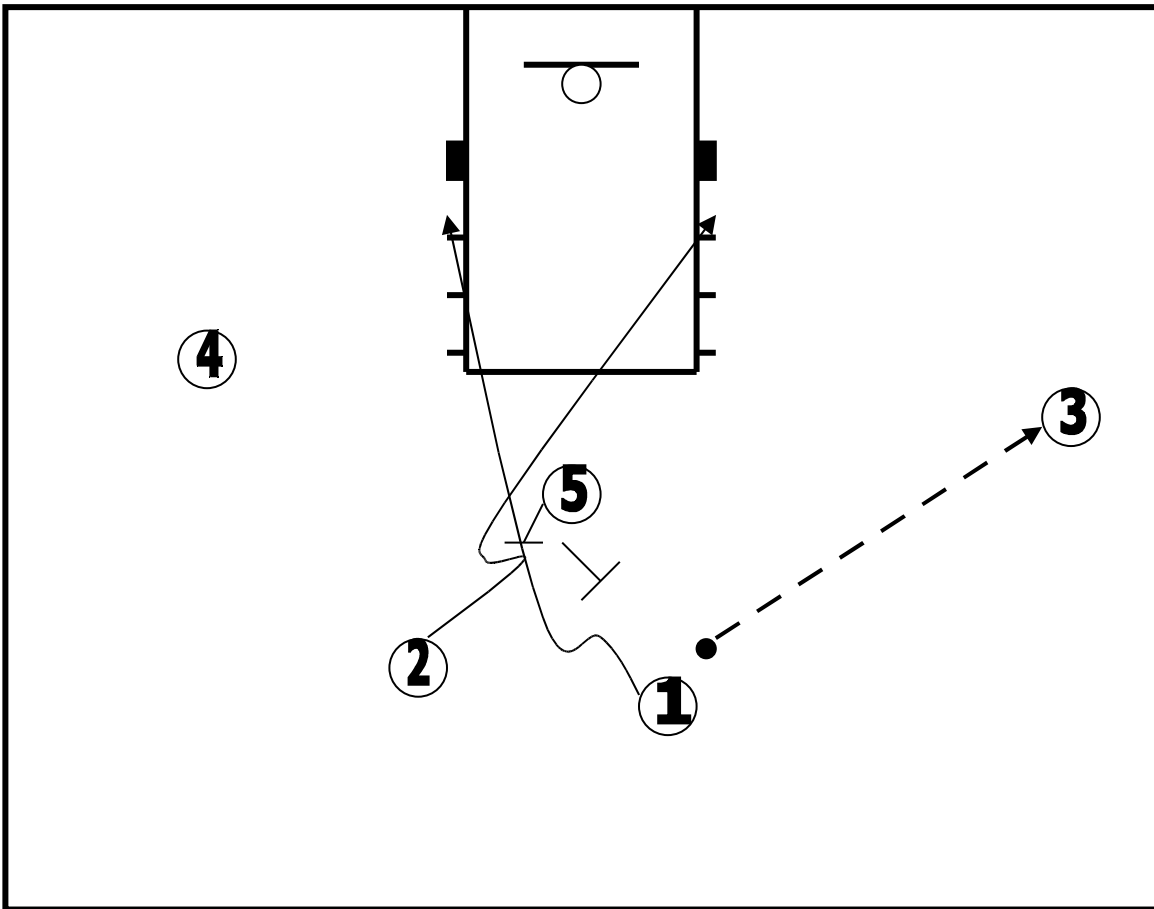

Special Set: "Shirt" (A)

Players are in a 2-3 alignment  
1 passes to 3  
2 cuts off 5, 1 then cuts off 5  
4 sprints to the top of the key for ball reversal

### Part 5 Special Sets

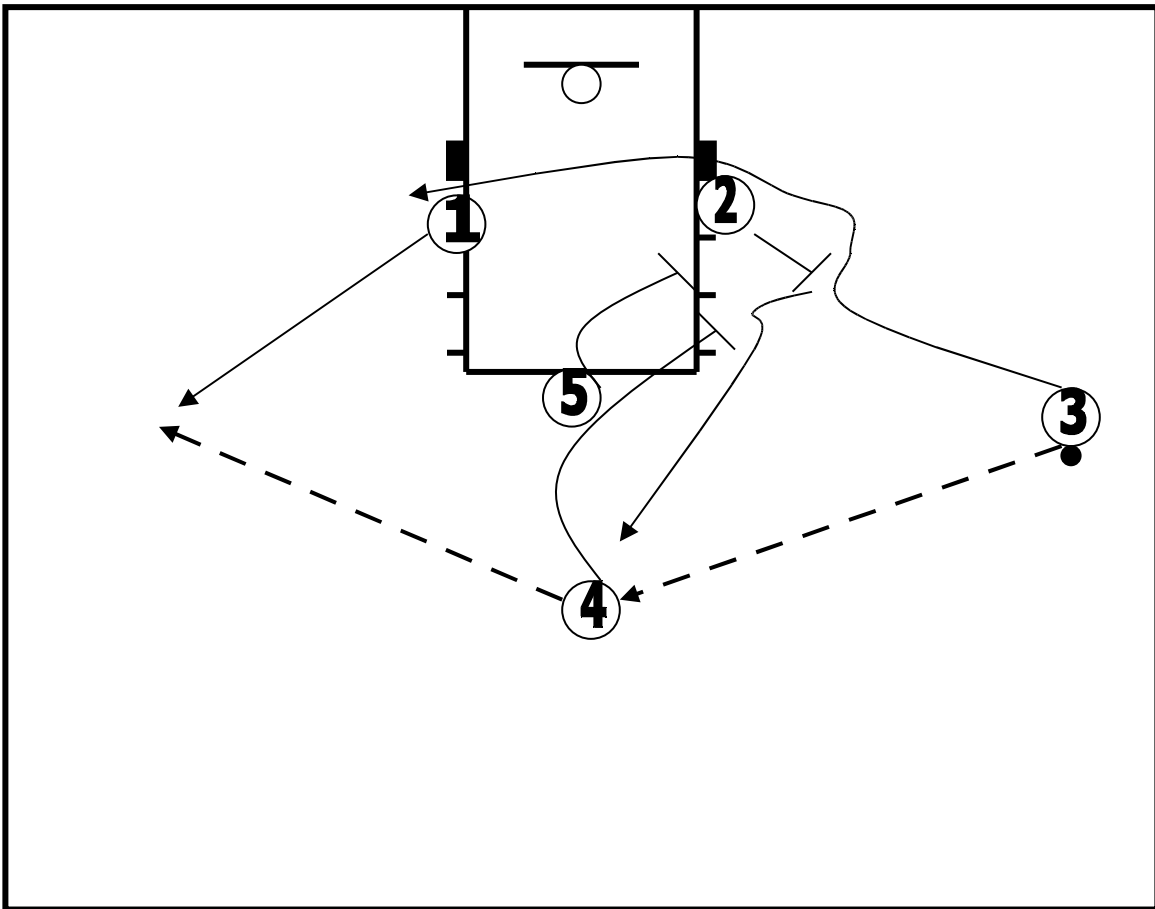

Special Set: "Shirt" (B)

3 passes to 4 for ball reversal

1 cuts hard to wing for ball reversal from 4

on flight of the ball from 4 to 1, 3 cuts off 2's back screen for a lay up

If 3's not open, 1 can pass to 2 off a double-staggered screens by 5 and 4

### Part 5 Special Sets

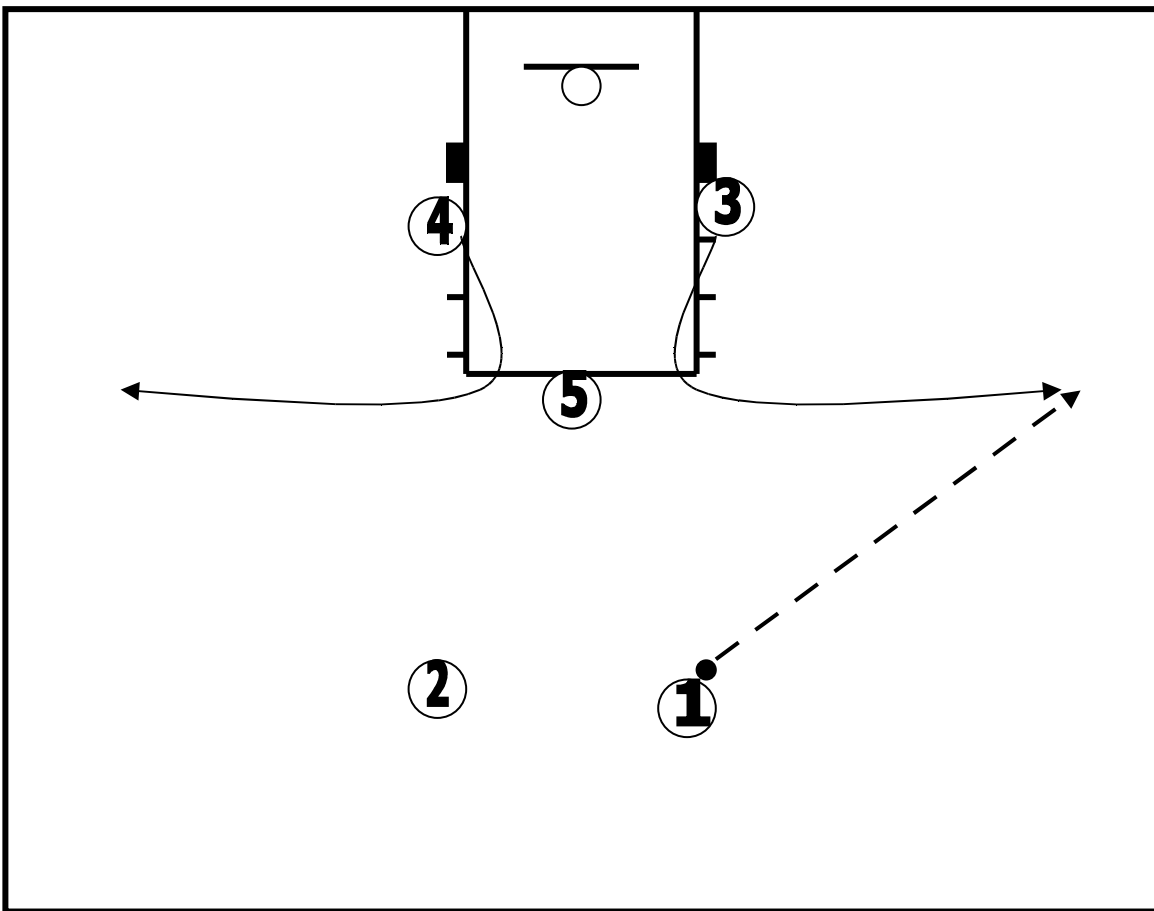

“Lob” play set (A)

3 and 4 “L” cut out  
1 passes to 3  
5 occupies the high post

### Part 5 Special Sets

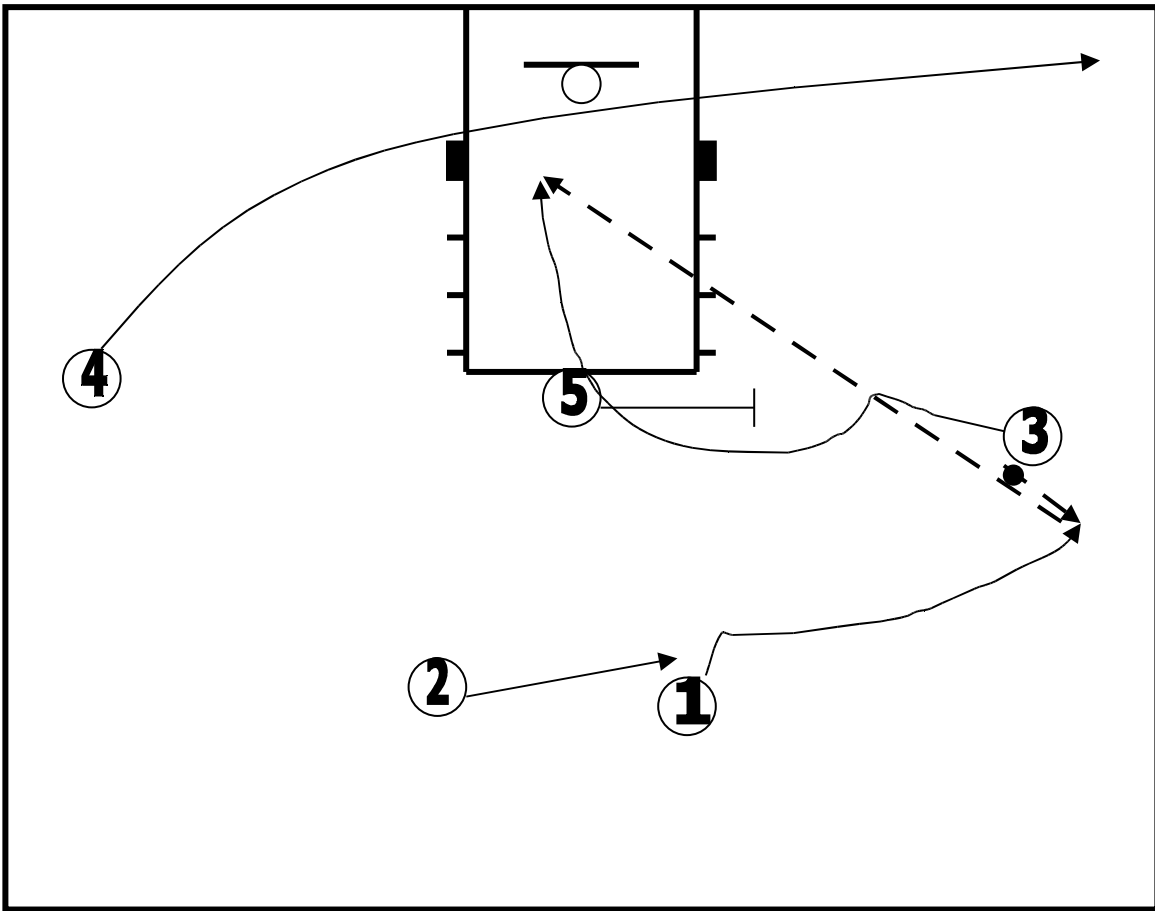

“Lob” play set (B)

On the pass from 1 to 3, 4 dead sprints to ball side corner  
At the same time, 1 fakes away and comes to get a flip back pass from 3  
3 now runs his man off 5's screen for a lob from 1  
2 must fill ball-side guard spot to take away help

### Part 5 Special Sets

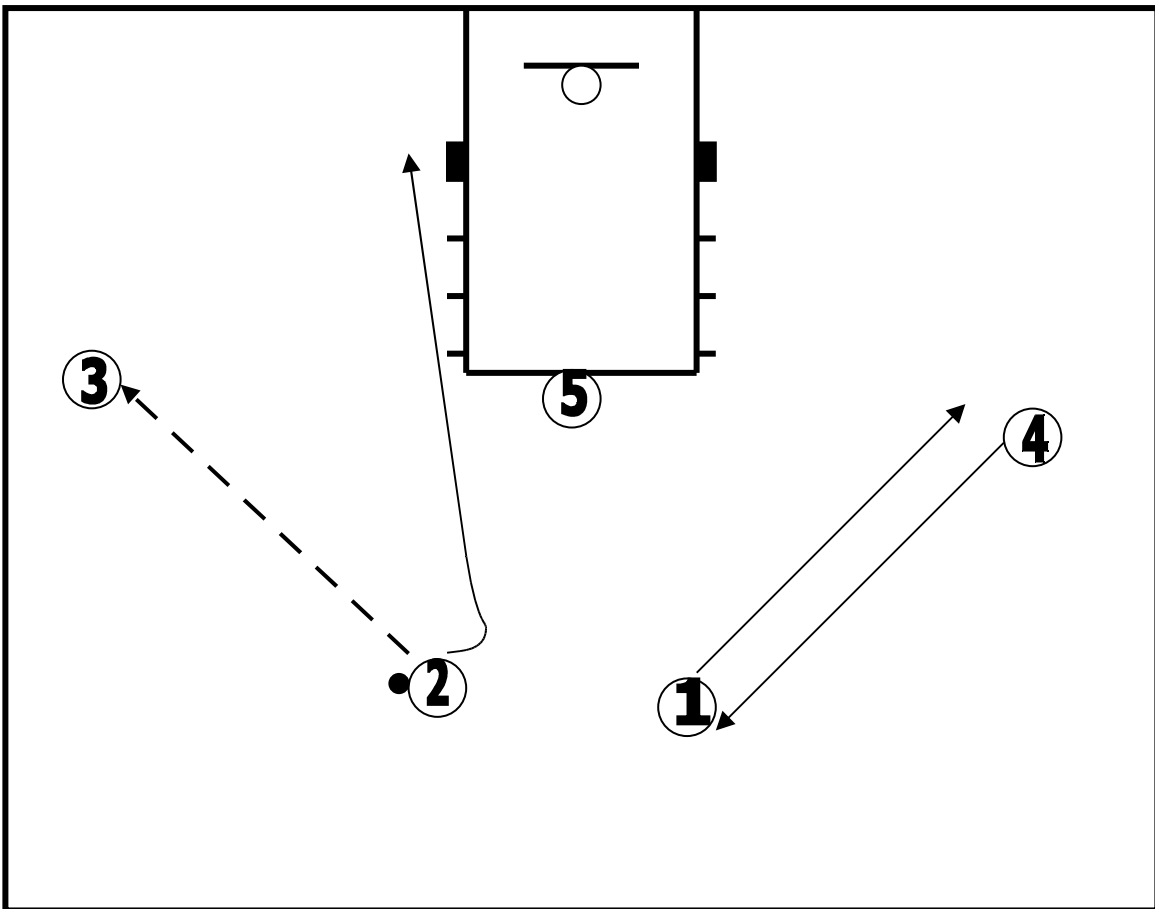

“Sprint” pressure release (A)  
2 passes to 3, then basket cuts hard  
1, 4 are interchanging weak side  
5 occupies the high post

Part 5 Special Sets

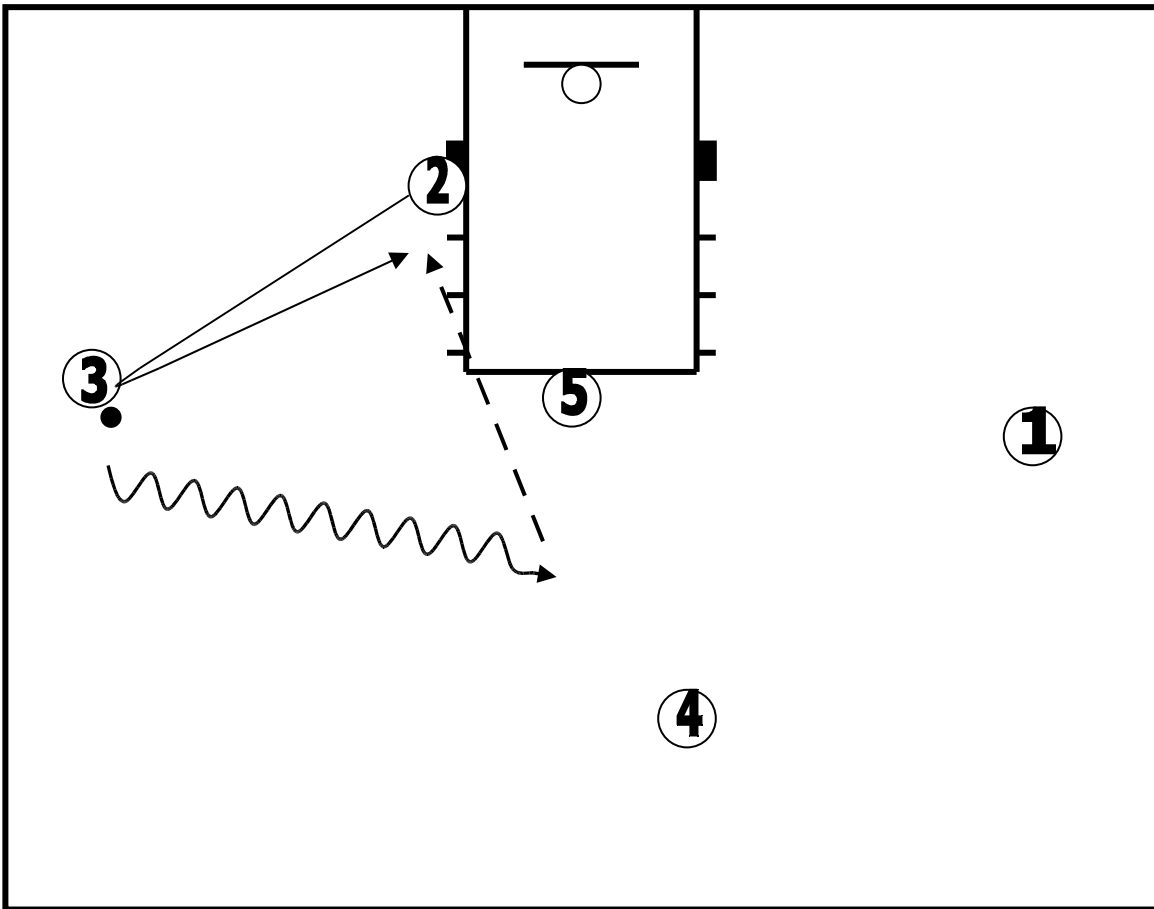

“Sprint” pressure release (B)

3 has the ball. As soon as 2 has reached the block, 3 dribbles hard to the top of the key

After basket cutting, 2 sprints to replace 3 on the wing

When 3 gets to top of the key, he jump stops, reverse pivots and ball fakes 2  
2 back doors his man for an easy lay up

#### Part 5 Special Sets

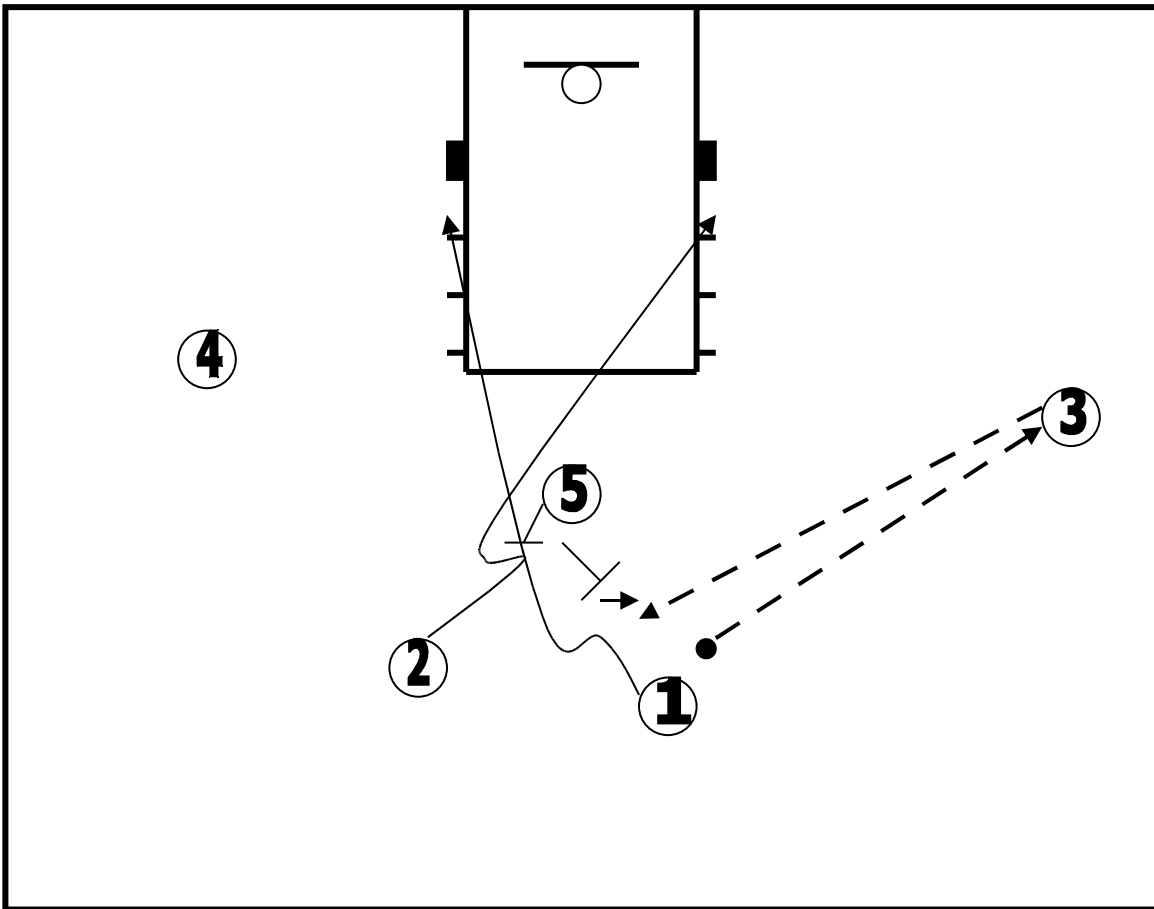

“UCLA” for a 3 point shot (A)

1 passes to 3: on the flight of the pass, 5 back screens for 2, then back screens for 1  
5 then steps out for ball reversal

### Part 5 Special Sets

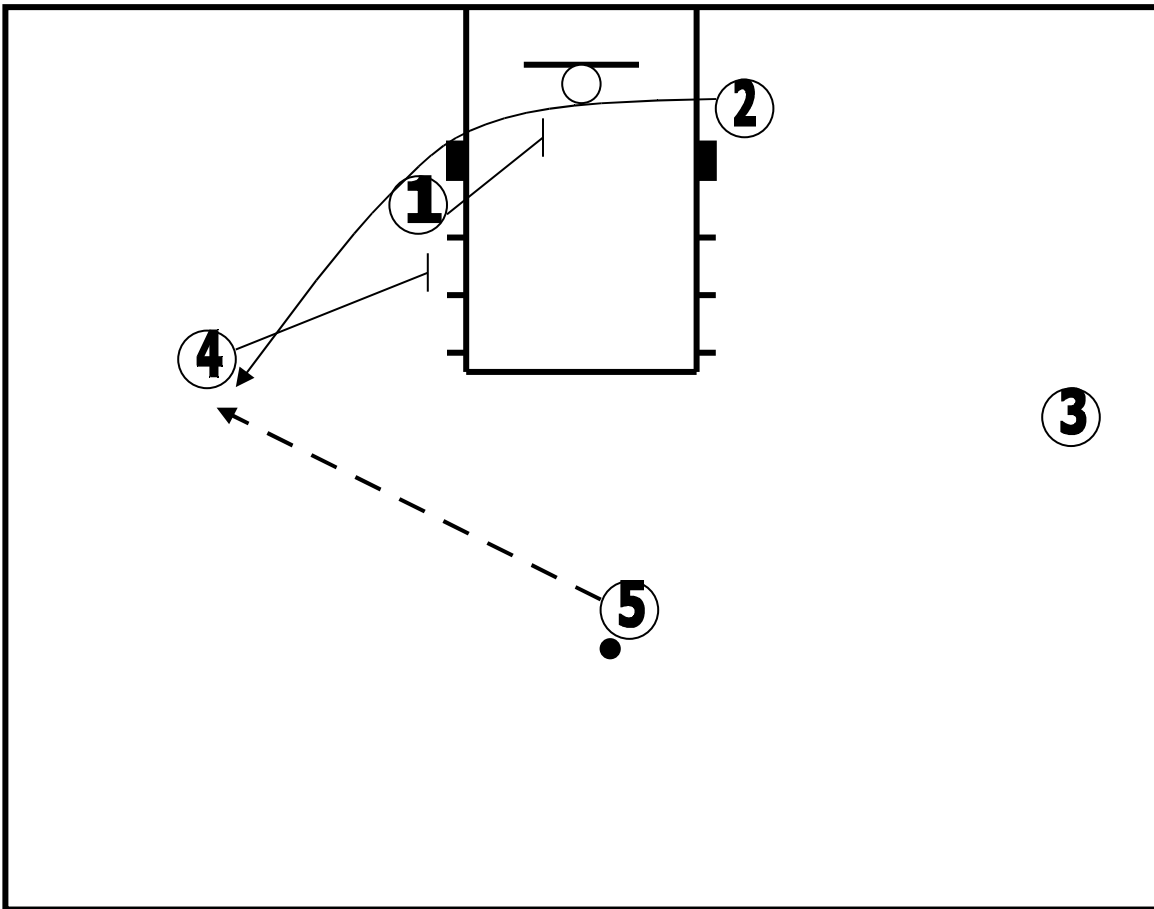

“UCLA” for a 3 point shot (B)



5 now has the ball

2 is now coming off a double staggered screen for open 3 point shot

### Part 5 Special Sets

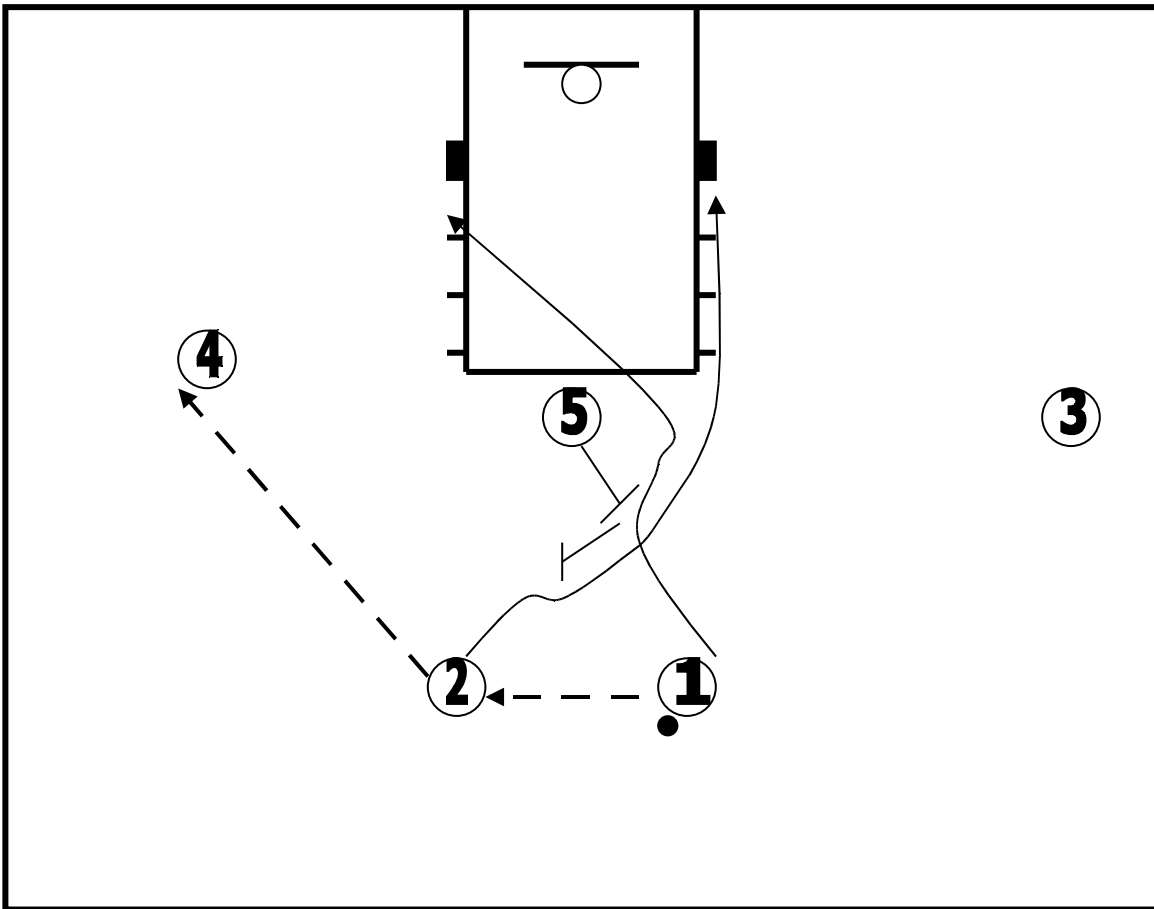

“Shuffle Cut” Series: More options (A)

Players are in a 2-3 alignment

1 reverses the ball to 2, 2 passes to 4

On the flight of the ball from 2 to 4, 5 back screens for 1, then 2

### Part 5 Special Sets

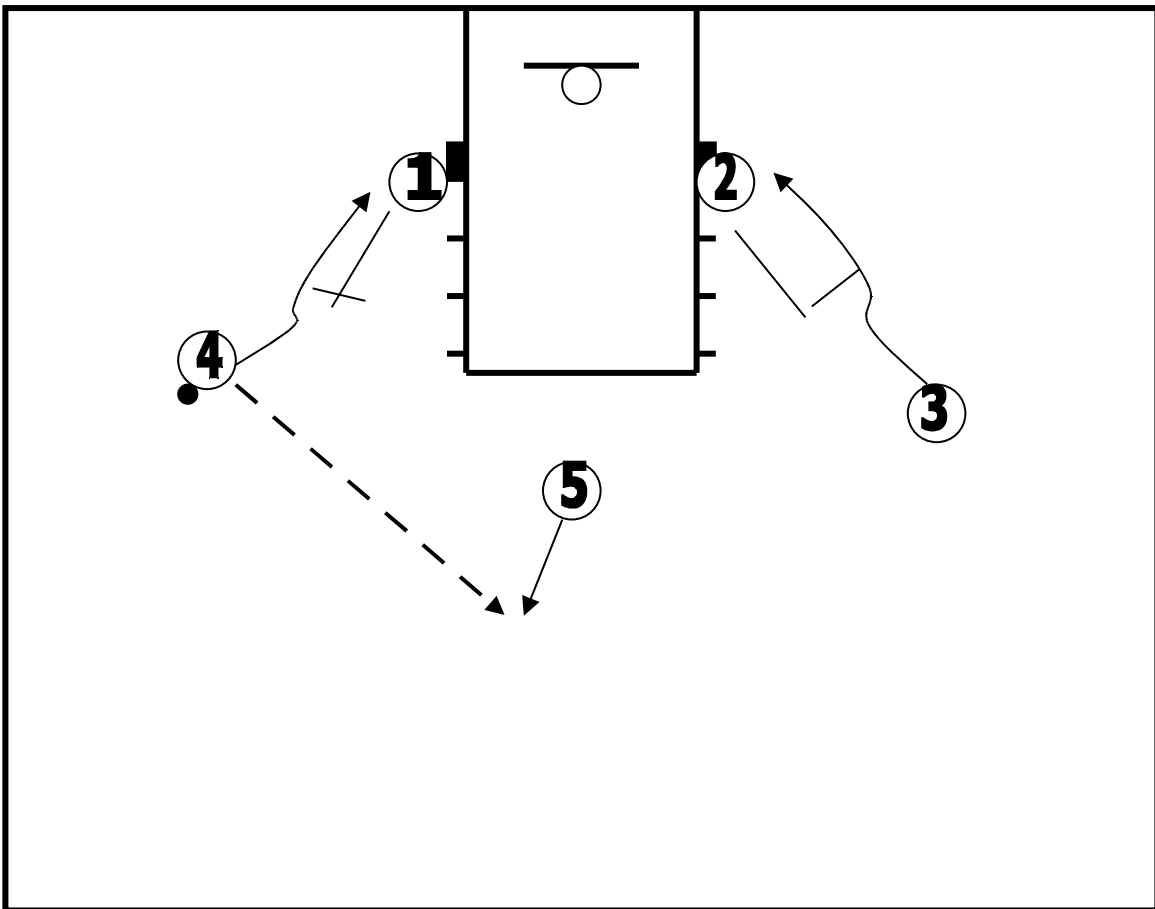

“Shuffle Cut” Series: More options (B)

5 steps out for a pass from 4

1 now back screens for 4, 2 back screens for 3

5 is looking for 4 or 3 for an easy lay up

5 also looks to pass to 1 or 2 on a step out for a jump shot

### Part 5 Special Sets

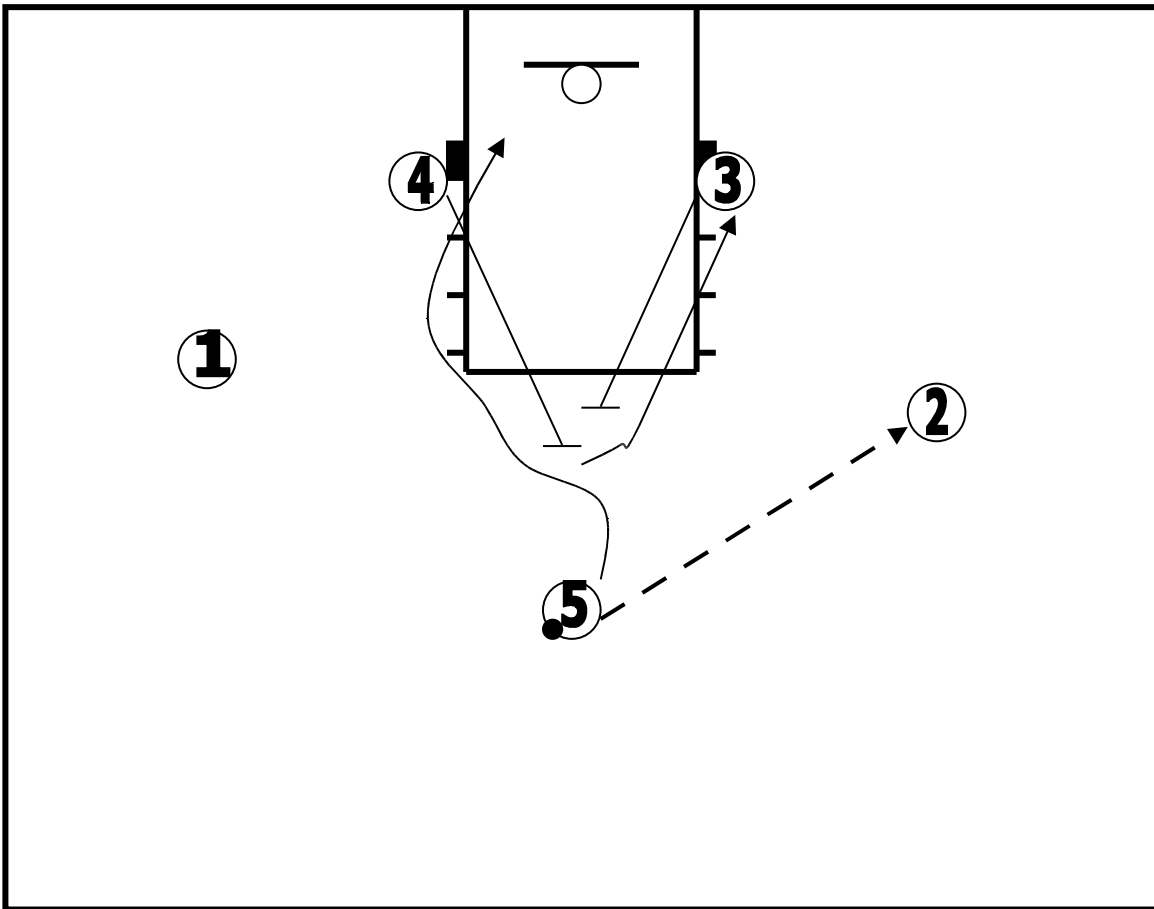

“Shuffle Cut” Series: More options (C)

5 passes to 2 on a step out  
4 sets back screen for 5, looking for a lob  
3 now sets an up screen for 4 looking for 4 rolling to the hoop off the screen

Break down drills #1

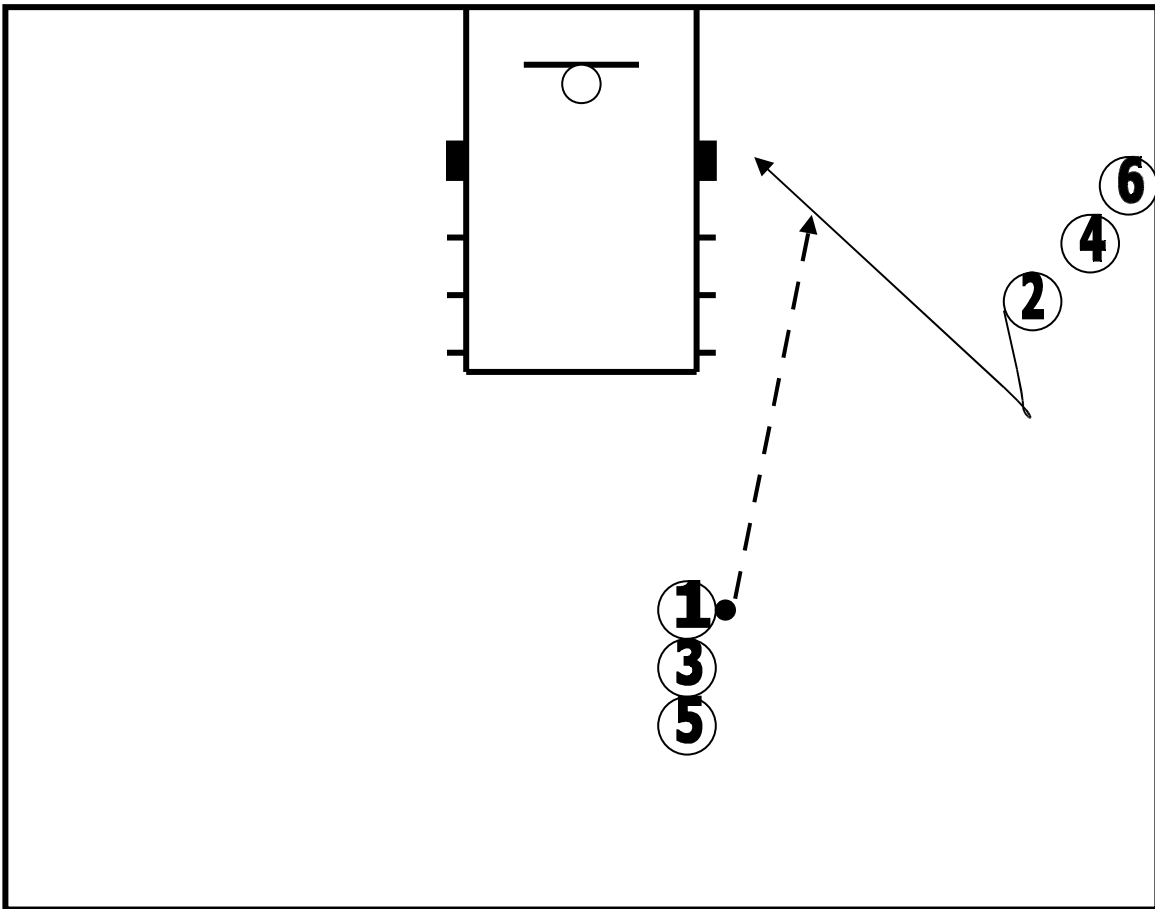

Break down drill #1

O1 dribbles hard at O2  
O2 fakes high, back doors for a lay up  
Pass must be a bounce pass leading players to the basket  
Make sure players are cutting in straight line to the basket  
Go from both sides

Break down drills #2

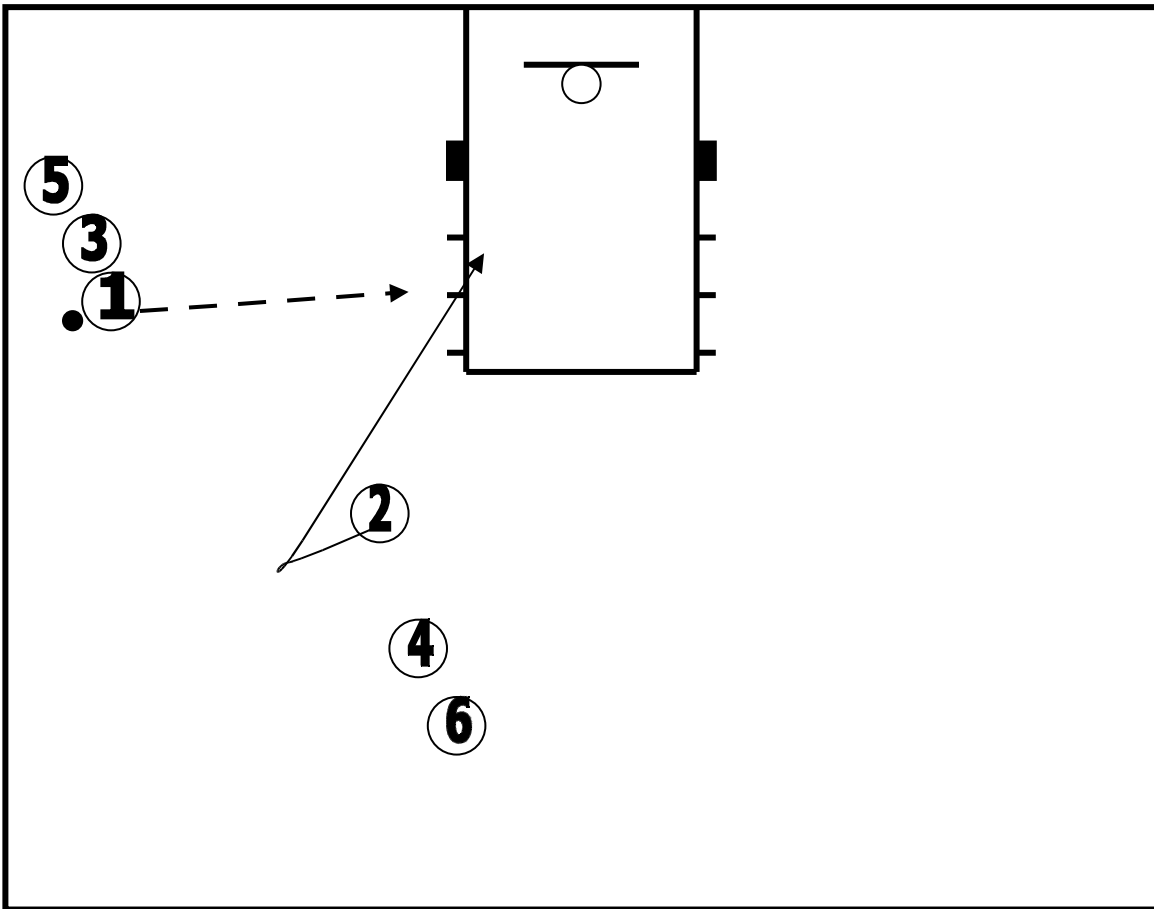

Break down drill #2

Same drill as #1, just different location  
O1 dribbles hard at O2, who fakes high and cuts back door  
Same teaching points as drill #1  
Go from both sides of the floor

Break down drills #3

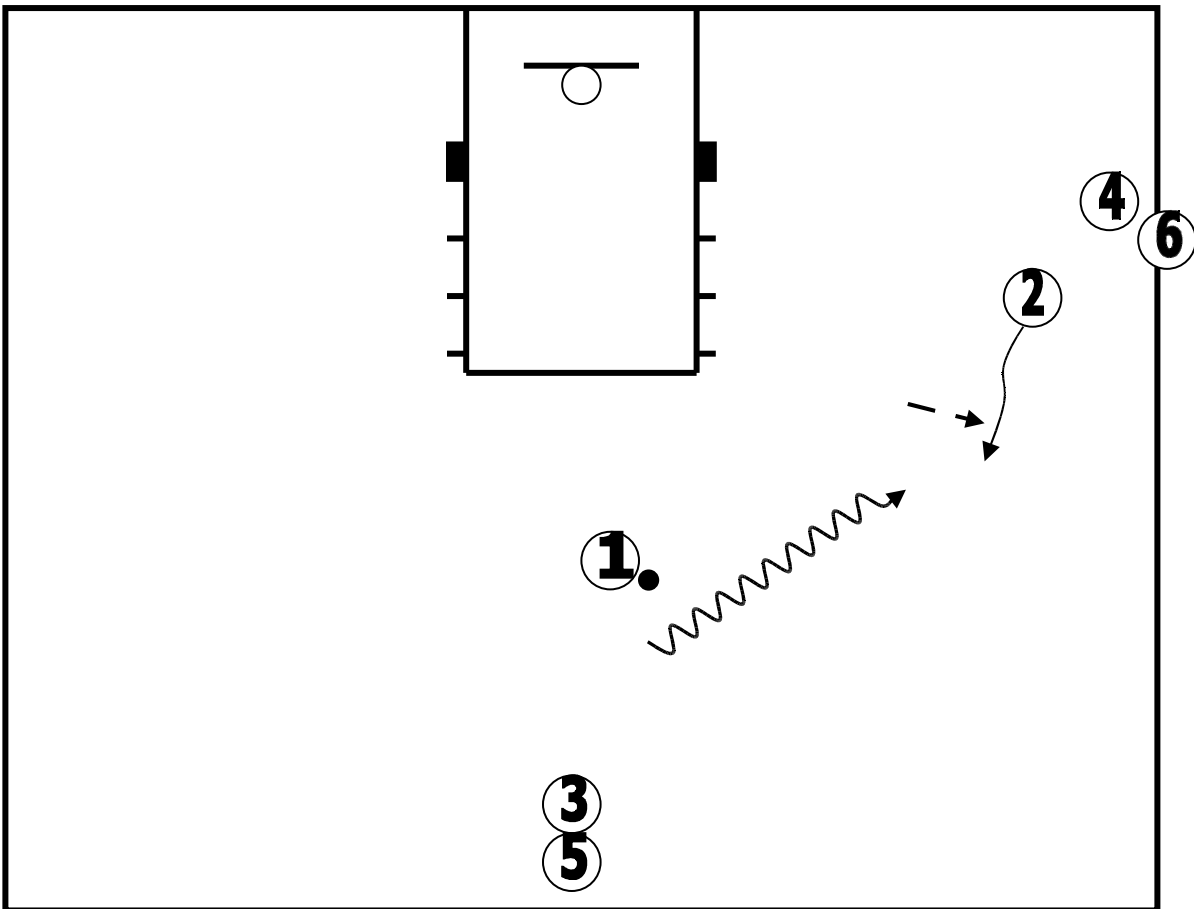

Break down drill #3

O1 dribbles hard at O2. O2 accepts dribble hand off from O1. O1 must dribble directly at O2's defender

O2 now has 3 options

A. O2 can shoot off the hand off

B. He can drive straight to the hoop

C. He can take the ball , dribble hard, and pass to O1 on the back door

Break down drills #3 (cont.) Option A

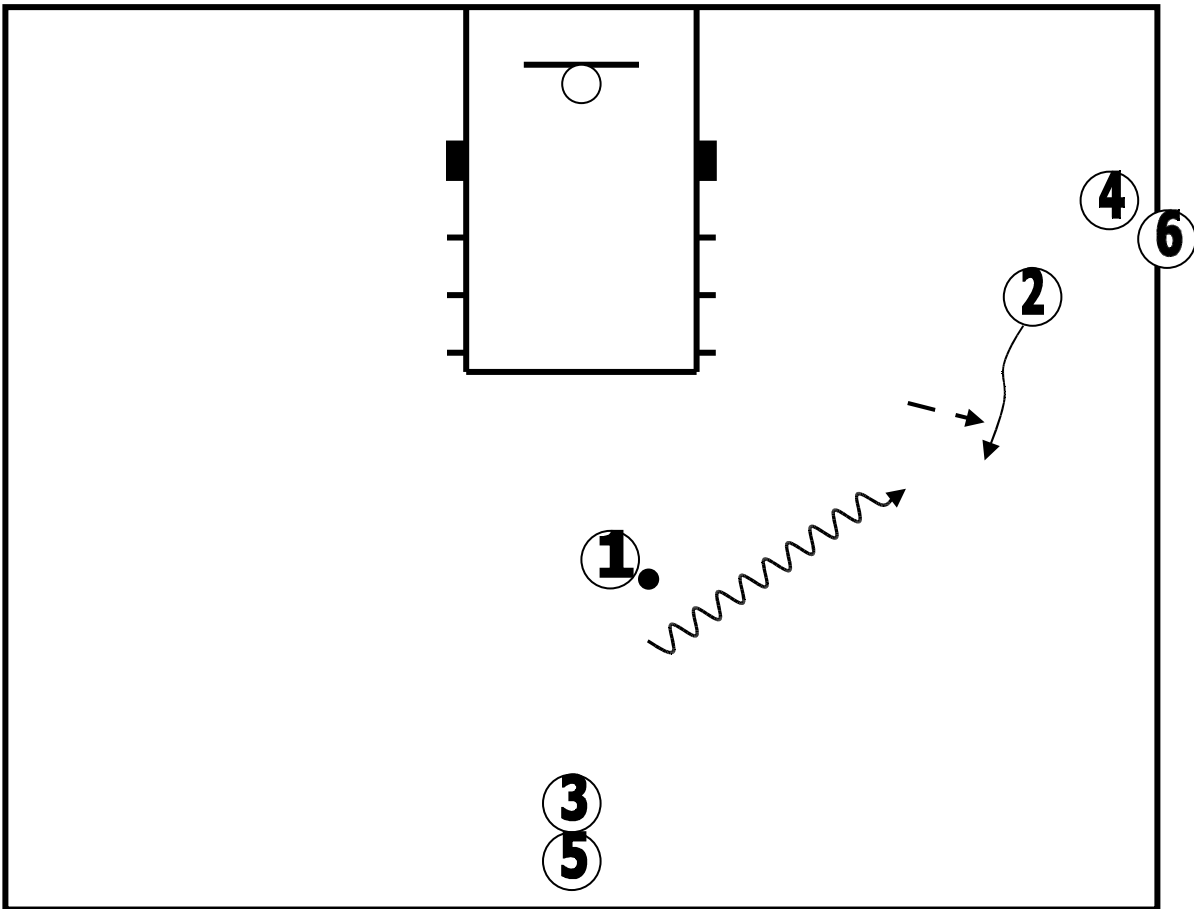

Break down drill #3

O2 has ball off the hand off and shoots a jump shot  
Go from several locations on the floor

Break down drills #3 (cont) Option B

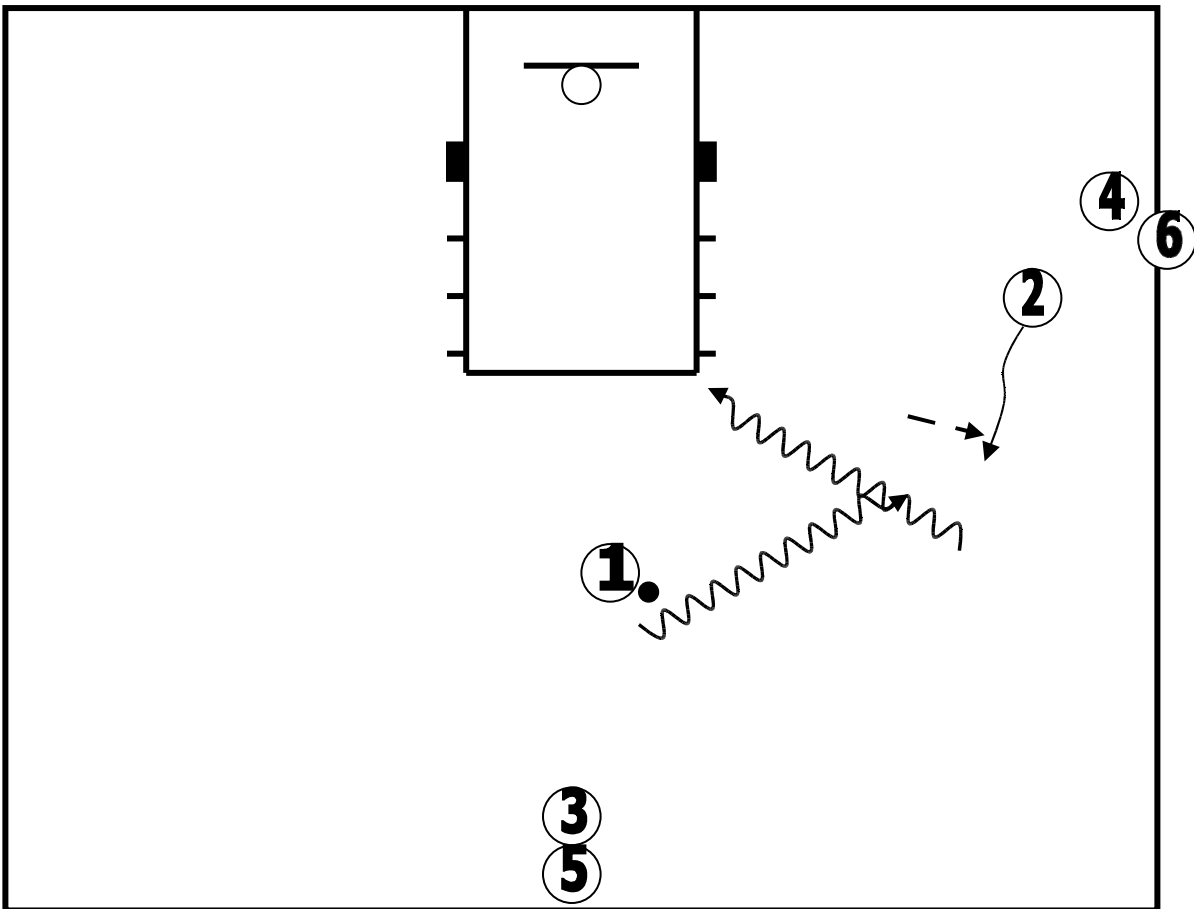



Break down drill #3

O2 has received dribble hand off from O1

O2 takes hand off and dribbles straight to the hoop

Break down drills #3 (cont) Option C

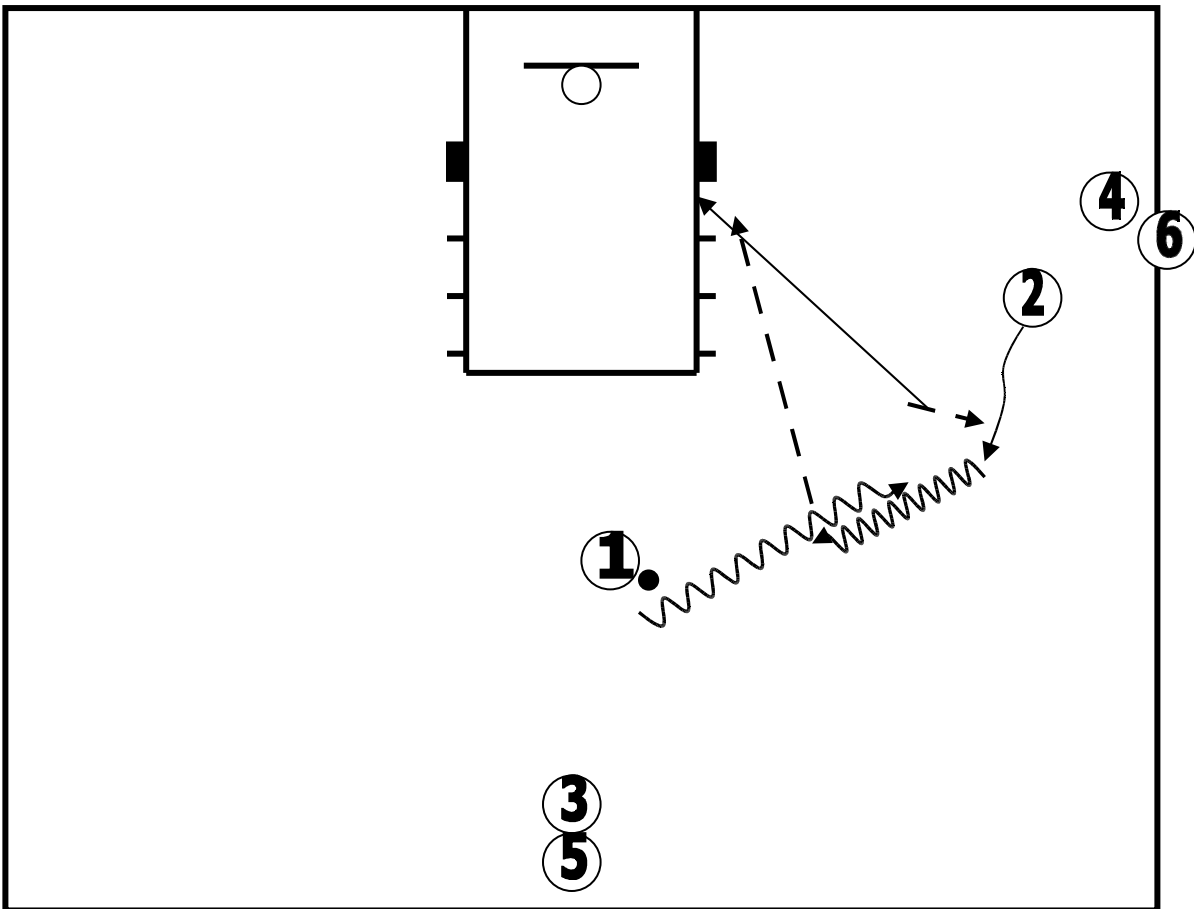

Break down drill #3 option C

O2 has received dribble hand off from O1

O2 dribbles hard, jump stops, reverse pivots, passes to O1 with a back door pass

Break down drills #4

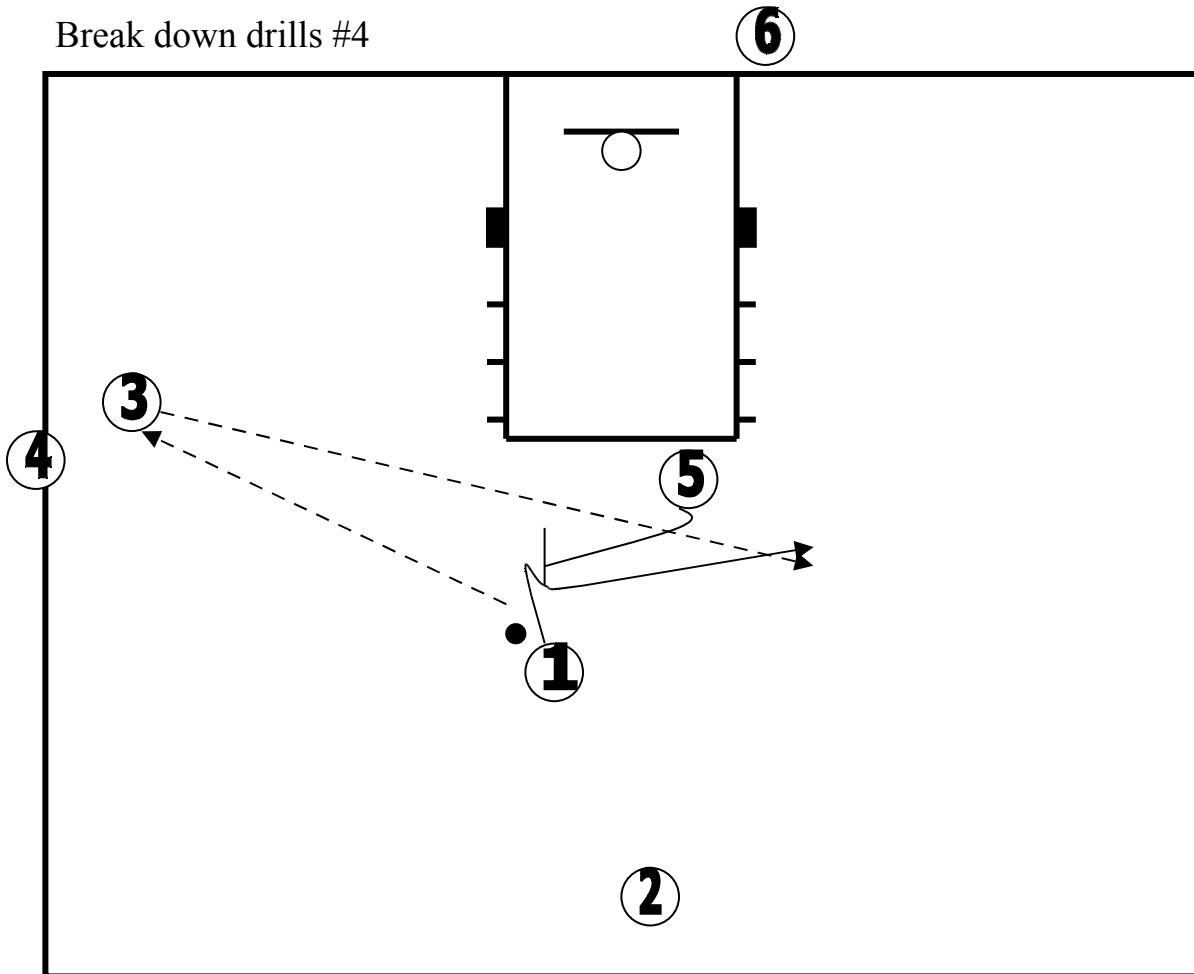

Break down drill #4

O1 passes to O3, O1 cuts in and fades off a flare from O5

O1 must cut hard to create proper screening angle for O5

O1 can shoot jumper or drive to the hoop

Go from both sides

Break down drills # 5

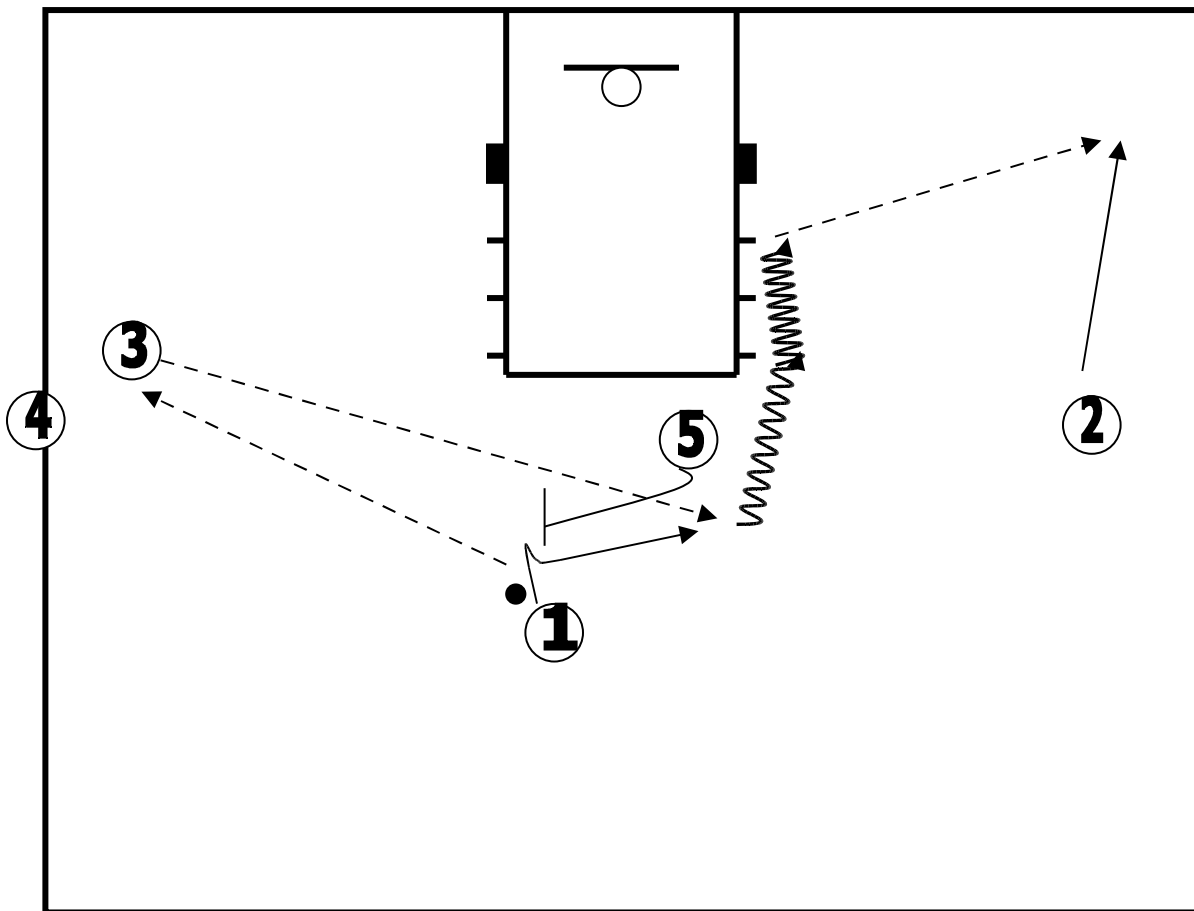

Break down drill #5

O1 passes to O3, cuts in, receives flare screen from O5

O3 passes to O1 and O1 drives to the hoop and pitches to O2 for a jump shot

Go from both sides of floor

5 must work religiously at getting himself in good screening position/angles